

MESSRS.

SPECIFICATION FOR APPROVAL

承 認 書

Product	MAGNETIC BUZZER
Part No.	AC-1612J-PF
Customer Approval	

Approved By	Checked By	Made By
		工程 許俊程 JAN-28



ADVANCED ACOUSTIC TECHNOLOGY CORP.

苙 翔 科 技 股 份 有 限 公 司



ISO 9001 Certified

2F, No.207, Sec. 6, Chung Shan N. Rd., Taipei, Taiwan, R.O.C.

Tel: +886-2-88665255

Fax: +886-2-88665250

E-mail: aat_mail@seed.net.tw

AC-1612J-PF

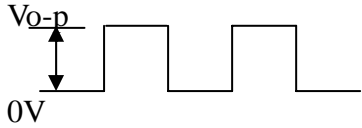
Items		Units	Specifications				Conditions
01	Rated Voltage	Vo-p	12				
02	Operating Voltage	Vo-p	8~15				
03	Mean Current	mA (Max)	50				Applying rated voltage, rated frequency Square wave, 1/2 duty subject to standard state.
04	Direct Current Resistance	Ohm	115±12				
05	Sound Output	dBA (min)	92				Distance at 10cm, applying rated voltage, rated frequency square wave, 1/2 duty subject to standard state.
06	Rated Frequency	Hz	2800				
07	Operating Temp.	°C	-40 ~ +85				
08	Storage Temp.	°C	-50 ~ +95				
09	Dimension	mm	Φ	16	Height	14	See attached drawing.
10	Weight	Gram	5				
11	Terminal		Two Pin				See attached drawing.

※Standard Drive Circuit:

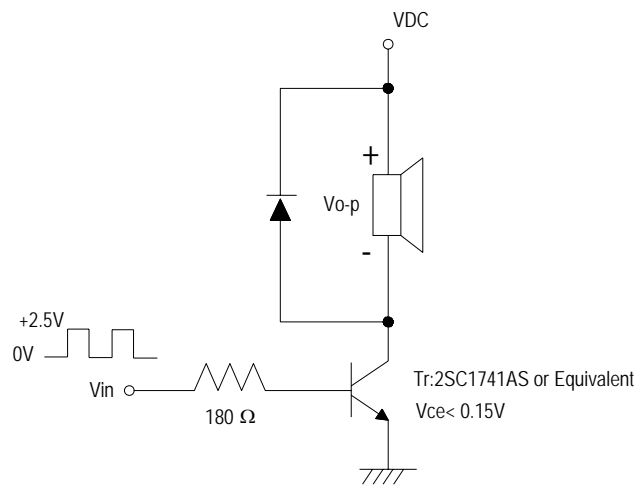

※Standard Conditions:

Temperature 15 ~ 35°C

Humidity 25 ~ 80 %

Air pressure 860 ~ 1060 HPa.

If the result is doubtful, should retested with the conditions below: Temp. 20±2°C, Humidity 60 ~ 70 %, Air pressure 860 ~ 1060 HPa.

※Note: As this product is not protected from foreign material entering, please make sure that any foreign materials (e.g. magnetic powder, washing solvent, flux, corrosive gas) do not enter this product in your production processes. The functional degradation (e.g. SPL down) may occur if foreign material enters it.

STANDARD TEST FIXTURE

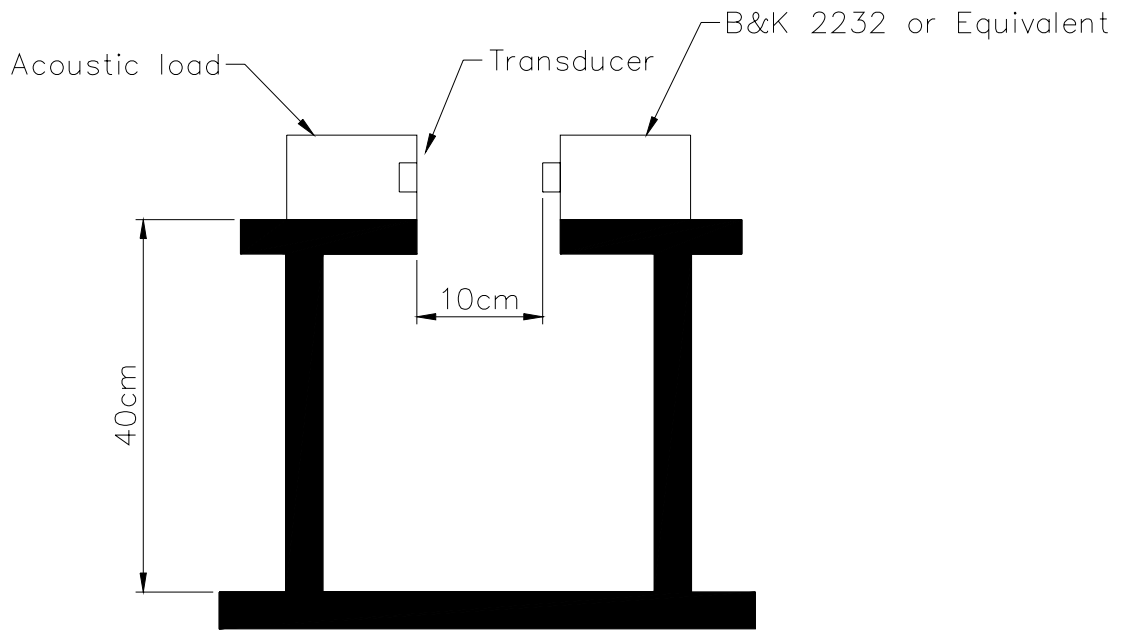

Standard test condition of magnetic buzzer

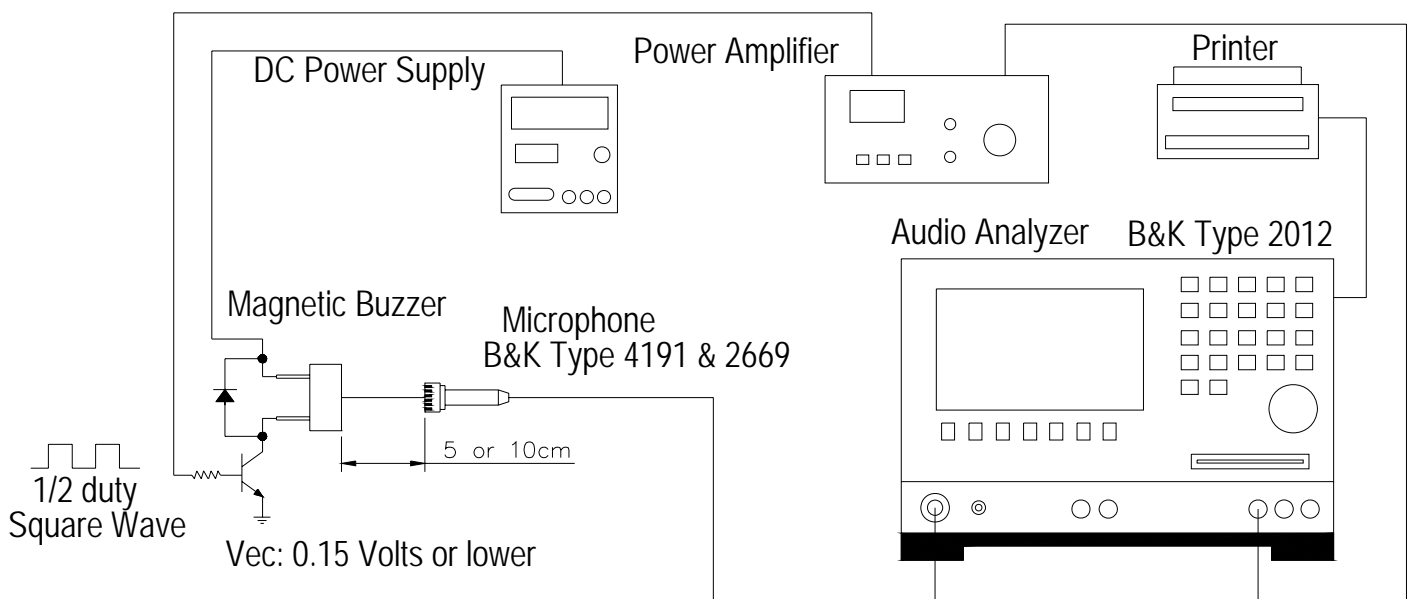

REV NO.

REVISION NOTE

APPROVAL

DATE

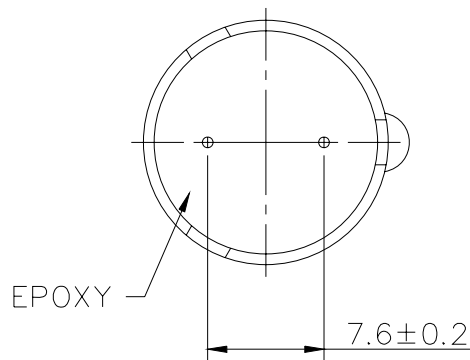
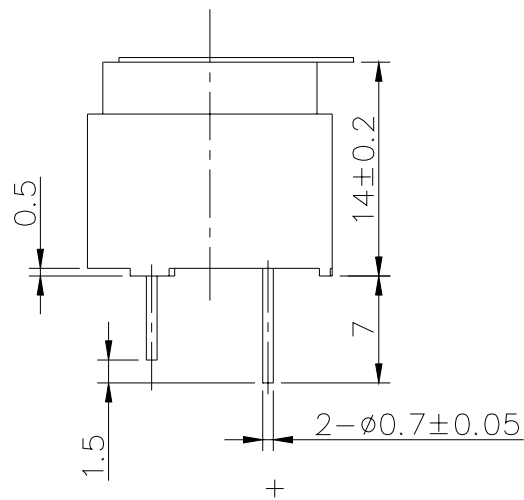
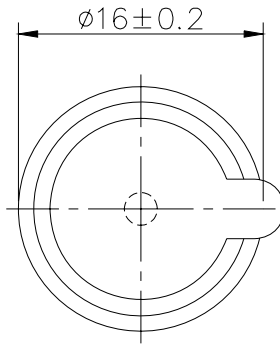

TITLE: SOUND TRANSDUCER		DRAWN: JOHN 01/27/2003	SCALE: 3:1	SHEET: 1 of 1
PART NO. AC-1612J-PF		DESIGNED: R&D OF AAT	UNITS: mm	
DWG NO. DTE-2071		CHECKED:	TOLERANCE ± 0.5	
		APPROVAL:	UNLESS OTHERWISE SPECIFIED: ONE PLACE DECIMAL ± *** TWO PLACE DECIMAL ± *** THREE PLACE DECIMAL ± ***	
REV 1		MATERIAL: NORYL		



苙翔科技股份有限公司
ADVANCED ACOUSTIC TECHNOLOGY CORPORATION

X:2.8184kHz Y:95.01dB ZA:Live Curve SSR T. RMS

PAF Frequency Response, Magn dB re 20.00

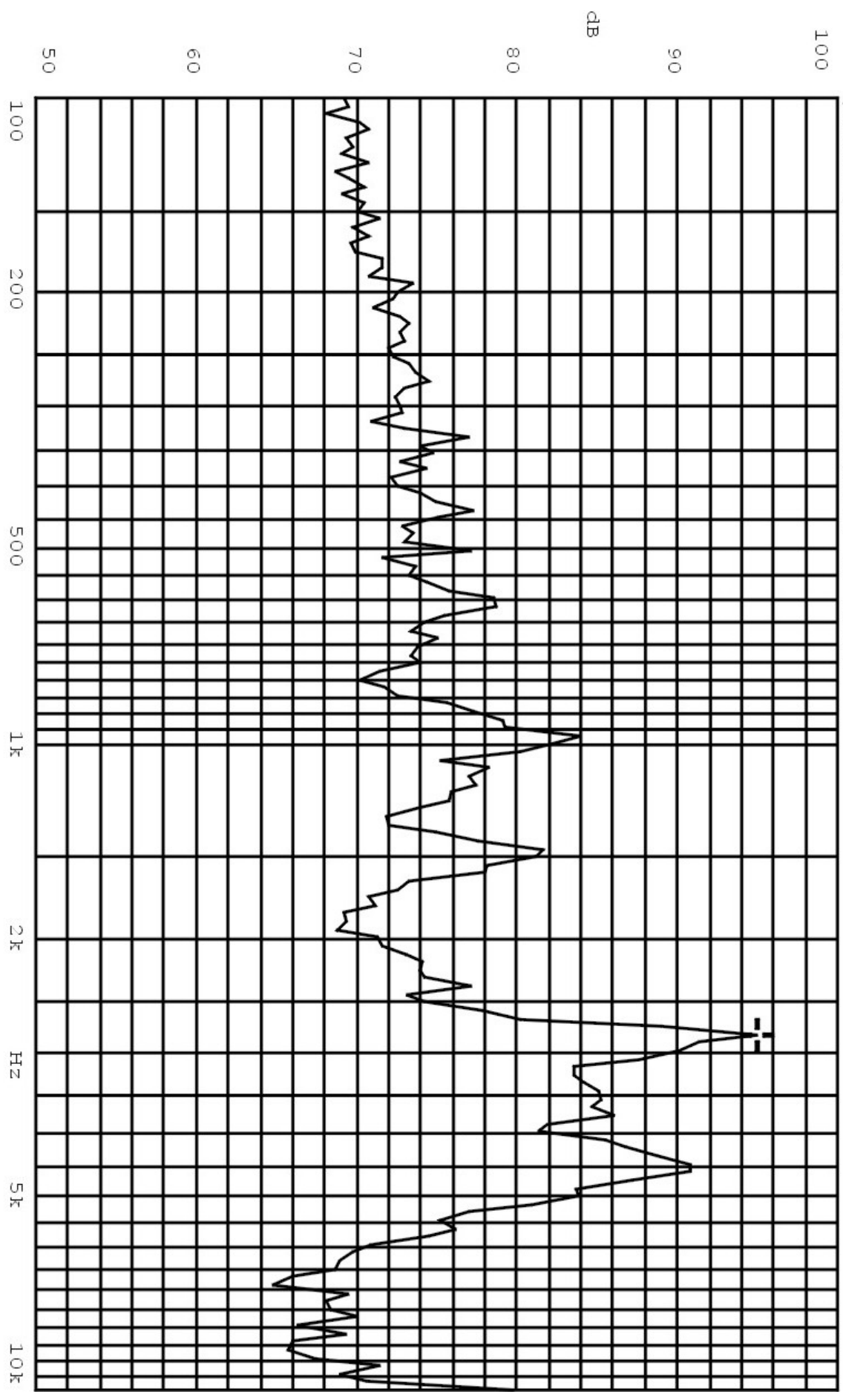

ADVANCED ACOUSTIC TECHNOLOGY CORP.

苙翔科技股份有限公司

AC-1612J-PF RELIABILITY TEST

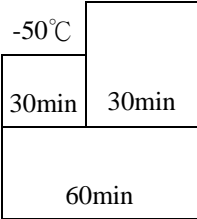
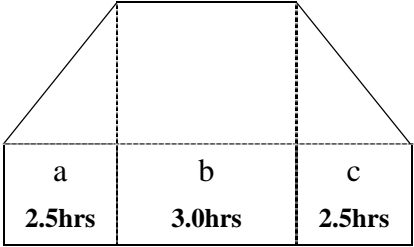
Item	Test conditions	Evaluation standard
01 High temp. Storage life	The part shall be capable of withstanding a storage Temperature of 95°C for 96 hours.	After the test the part shall meet specifications without Any degradation in appearance and performance except S.P.L S.P.L shall be 84dB or more.
02 Low temp. Storage life	The part shall be capable of withstanding a storage Temperature of -50°C for 96 hours.	
03 Temp.cycle	<p>The part shall be subjected 10 cycles. One cycle shall consist of;</p> 	
04 Temp./Humidity cycle	<p>The part shall be subjected 10 cycles. One cycle shall be 8 hours and consist of;</p>  <p>a,b:90~98%RH c :80~98%RH</p>	

ADVANCED ACOUSTIC TECHNOLOGY CORP.

苙翔科技股份有限公司

AC-1612J-PF RELIABILITY TEST

Item	Test conditions	Evaluation standard
05 Vibration	The part shall be subjected to a vibration cycle of 10Hz to 55Hz to 10Hz in a period of 1 minute. Total peak amplitude shall be 1.52mm (9.3G). The vibration test shall consist of 2 hours per plane in each three mutually perpendicular planes for a total time Of 6 hours.	After the test the part shall meet specifications without Any degradation and performance except S.P.L S.P.L shall be 84dB or more.
06 Fixed drop	The part shall be mounted on 100g jig(standard pc board) and dropped from a height of 152cm onto a concrete floor 5 times in each 6 planes. (a total of 30 times)	
07 Free drop	The part only shall be dropped from a height of 75cm onto a 40mm thick wooden board 3 times in 3 axes (X.Y.Z). (a total of 9 times).	
08 Operating life	1. Ordinary temperature The part shall be subjected to 1000 hours at room temperature ($25 \pm 10^{\circ}\text{C}$) with 12V ,2800Hz applied. 2. High temperature The part shall be subjected to 500 hours at 85°C with 12V, 2800Hz applied. 3. Low temperature The part shall be subjected to 500 hours at -40°C with 12V, 2800Hz applied.	