

MESSRS.

SPECIFICATION FOR APPROVAL

承 認 書

Product	MAGNETIC BUZZER
Part No.	AS-303Q-F1P1
Customer Approval	

Approved By	Checked By	Made By



ADVANCED ACOUSTIC TECHNOLOGY CORP.

苙 翔 科 技 股 份 有 限 公 司



ISO 9001 Certified

4F, No.238, Sec. 6, Chung Shan N. Rd., Taipei, Taiwan, R.O.C.

Tel: +886-2-88665255

Fax: +886-2-88665250

E-mail: aat_mail@seed.net.tw

AS-303Q-F1P1

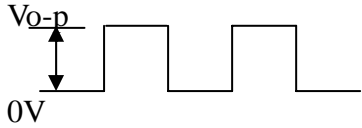
Items		Units	Specifications				Conditions
01	Rated Voltage	Vo-p	3.0				
02	Operating Voltate	Vo-p	2~4				
03	Mean Current	mA (Max)	100				Applying rated voltage,rated frequency Square wave,1/2 duty subject to standard state.
04	Direct Current Resistance	Ohm	15±2.0				
05	Sound Output	dBa (min)	85				Distance at 5cm,applying rated voltage,rated frequency square wave, 1/2duty subject to standard state.
06	Rated Frequency	Hz	2731				
07	Operating Temp.	°C	-40 ~ +85				
08	Storage Temp.	°C	-50 ~ +95				
09	Dimension	mm	Φ	10	Height	2.8	See attached drawing.
10	Weight	Gram	0.2				
11	Terminal		None				See attached drawing.

※Standard Drive Circuit:

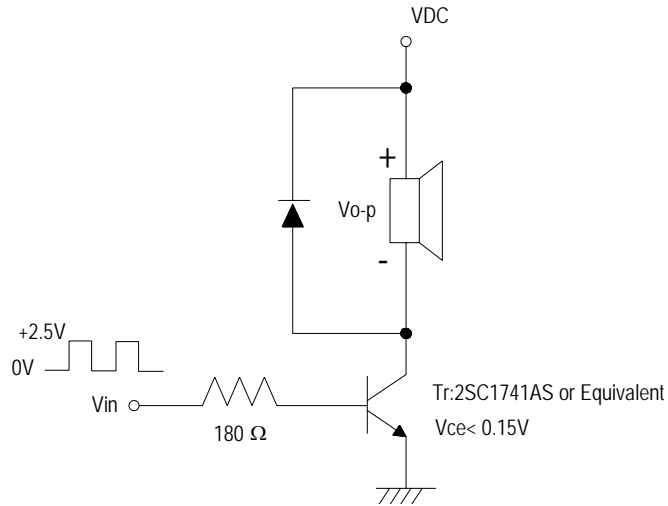

※Standard Conditions:

Temperature 15 ~ 35°C

Humidity 25 ~ 80 %

Air pressure 860 ~ 1060 HPa.

If the result is doubtful, should retested with the conditions below:Temp. 20±2°C, Humidity 60 ~ 70 %, Air pressure 860 ~ 1060 HPa.

Air pressure 860 ~ 1060 HPa.

※Note:As this product is not protected from foreign material entering,please make sure that any foreign materials(e.g. magnetic powder,washing solvend,flux,corrosive gas)do not enter this product in your production processes.The functional degradation(e.g. SPL down)may occur if foreign material enter it.

STANDARD TEST FIXTURE

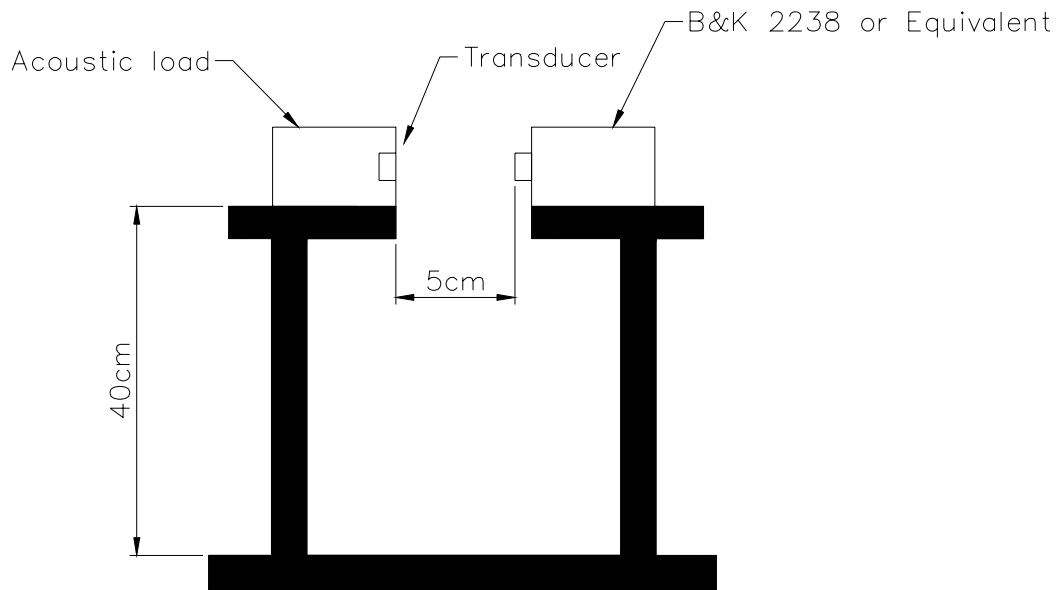

Standard test condition of magnetic buzzer

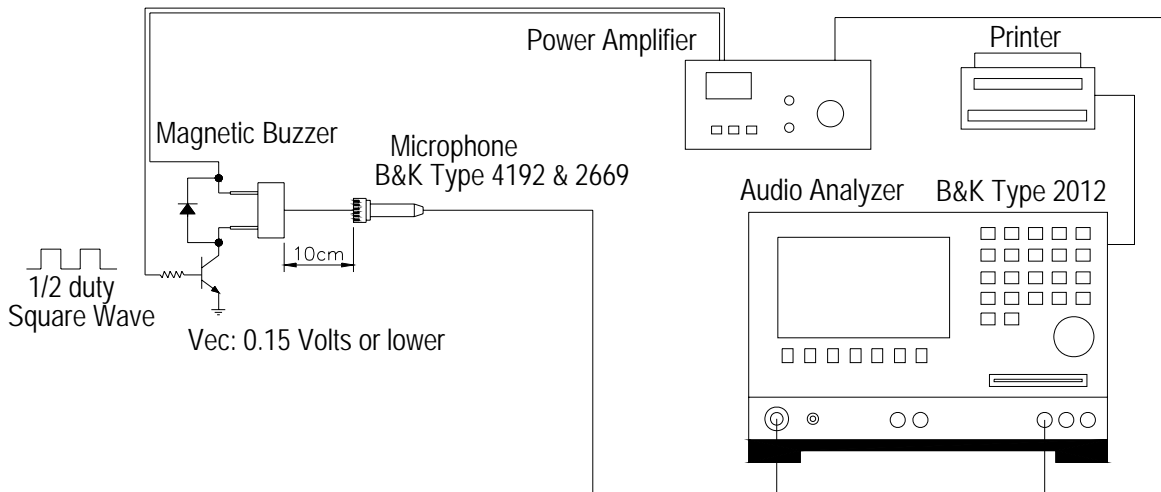

MODEL: AS-303Q-F1P1

X: 2.7384kHz

Y: 93.39dB

ZA: Live Curve

SSR T. RMS

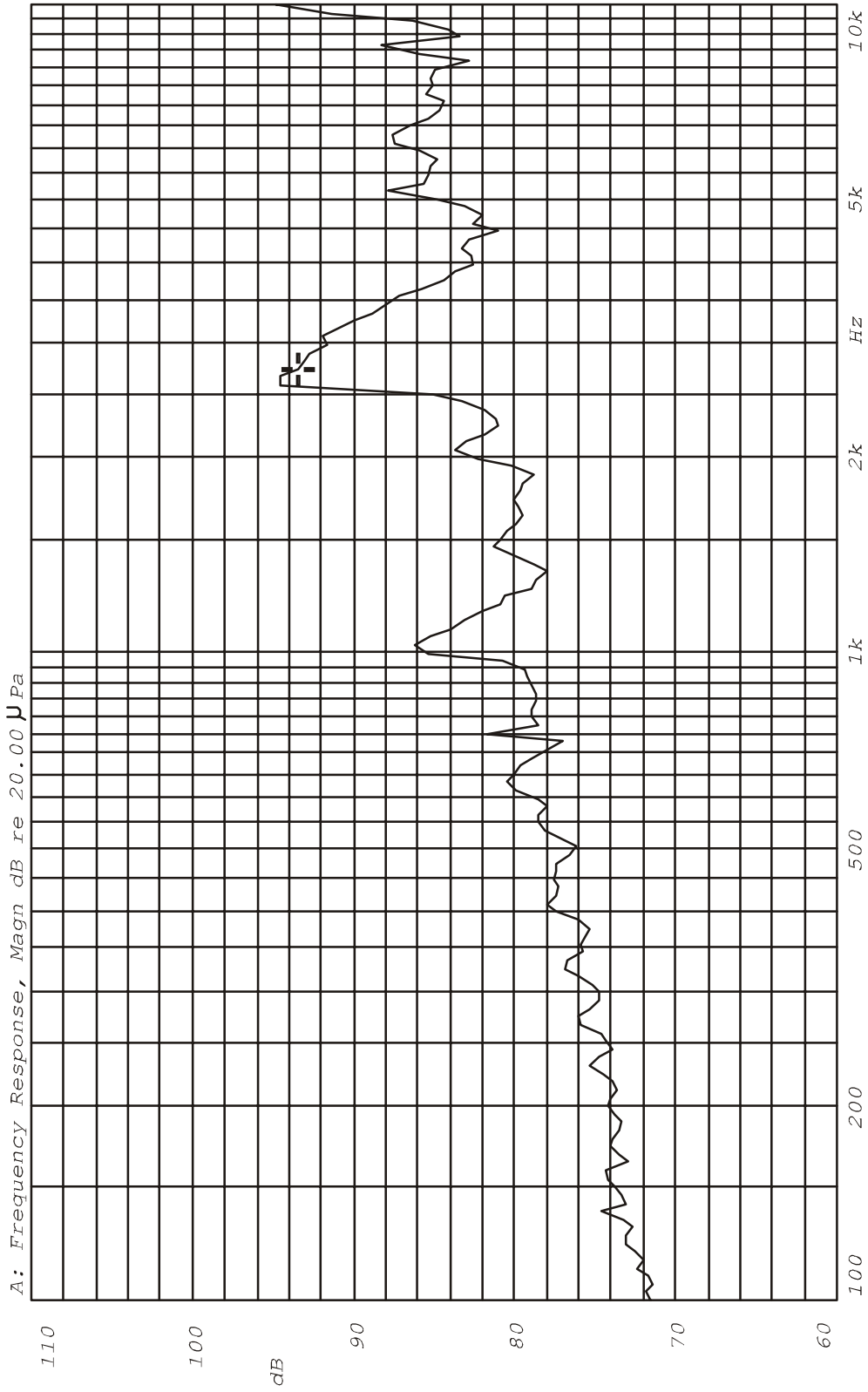

Mode: SSR

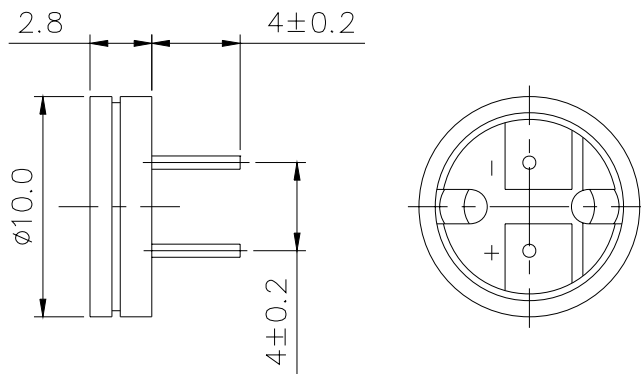

SOUND EMISSION HOLE $\phi 6.5$

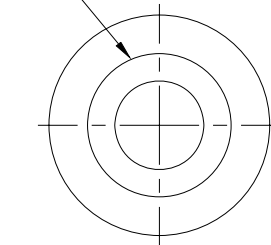

BACK VIEW

TITLE: SOUND TRANSDUCER DIMENSIONS		DRAWN: Milton 08/15/2001	SCALE: 3/1	SHEET: 1 OF 1
PART NO. AS-303Q-F1P1	1	DESIGNED: R&D OF AAT	UNITS: mm	
DWG NO. DTT-1091		CHECKED:	TOLERANCE ± 0.2	
	REV	APPROVAL:	UNLESS OTHERWISE SPECIFIED:	
		MATERIAL: PPO	ONE PLACE DECIMAL \pm ***	
			TWO PLACE DECIMAL \pm ***	
			THREE PLACE DECIMAL \pm ***	



苙翔科技股份有限公司
ADVANCED ACOUSTIC TECHNOLOGY CORPORATION

ADVANCED ACOUSTIC TECHNOLOGY CORP.

苙翔科技股份有限公司

RELIABILITY TEST

AS-303Q-F1P1

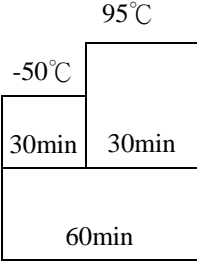
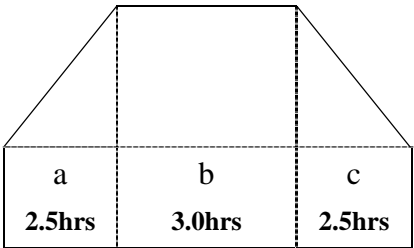
Item	Test conditions	Evaluation standard
01 High temp. Storage life	The part shall be capable of withstanding a storage Temperature of 95°C for 96 hours.	After the test the part shall meet specifications without Any degrance and performance except S.P.L S.P.L shall be 77dB or more.
02 Low temp. Storage life	The part shall be capable of withstanding a storage Temperature of -50°C for 96 hours.	
03 Temp.cycle	The part shall be subjected 10 cycles. One cycle shall consist of; 	
04 Temp./Humidity cycle	The part shall be subjected 10 cycles. One cycle shall be 8 hours and consist of;  <p style="text-align: center;">a,b:90~98%RH c :80~98%RH</p>	

ADVANCED ACOUSTIC TECHNOLOGY CORP.

苙翔科技股份有限公司

RELIABILITY TEST

AS-303Q-F1P1

Item	Test conditions	Evaluation standard
05 Vibration	The part shall be subjected to a vibration cycle of 10Hz to 55Hz to 10Hz in a period of 1 minute. Total peak amplitude shall be 1.52mm (9.3G). The vibration test shall consist of 2 hours per plane in each three mutually perpendicular planes for a total time Of 6 hours.	After the test the part shall meet specifications without Any degrance and performance except S.P.L S.P.L shall be 77dB or more.
06 Fixed drop	The part shall be mounted on 100g jig(standard pc board) and dropped from a height of 152cm onto a concrete floor 5 times in each 6 planes. (a total of 30 times)	
07 Free drop	The part only shall be dropped from a height of 75cm onto a 40mm thick wooden board 3 times in 3 axes (X.Y.Z). (a total of 9 times).	
08 Operating life	1. Ordinary temperature The part shall be subjected to 1000 hours at room temperature ($25 \pm 10^{\circ}\text{C}$)with 3V 2731Hz applied. 2. High temperature The part shall be subjected to 500 hours at 85°C with 3V, 2731Hz applied. 3. Low temperature The part shall be subjected to 500 hours at -40°C with 3V, 2731Hz applied.	