

# *MESSRS.*

---

## SPECIFICATION FOR APPROVAL

## 承 認 書

Product	MAGNETIC BUZZER INDICATOR
Part No.	AX-1212-P3
Customer Approval	

Approved By	Checked By	Made By



**ADVANCED ACOUSTIC TECHNOLOGY CORP.**

**苙 翔 科 技 股 份 有 限 公 司**



ISO 9001 Certified

2F, No.207, Sec. 6, Chung Shan N. Rd., Taipei, Taiwan, R.O.C.

Tel: +886-2-88665255

Fax: +886-2-88665250

# AX-1212-P3

Items		Units	Specifications				Conditions
01	Rated Voltage	VDC	12				Volts D.C.
02	Operating Voltage	VDC	9~15				Volts D.C
03	Mean Current	mA (Max)	30				Applying rated voltage
04	Direct Current Resistance	Ohm	None				
05	Sound Output	dBA (min)	85				Distance at 10cm, applying rated voltage
06	Basic Frequency	Hz	3100± 300				
07	Operating Temp.	°C	-40 ~ +85				
08	Storage Temp.	°C	-50 ~ +95				
09	Dimension	mm	Φ	12	Height	7.5	See attached drawing.
10	Weight	Gram	2				
11	Terminal		Two PIN				See attached drawing.

※Standard Conditions:

Temperature 15 ~ 35°C

Humidity 25 ~ 80 %

Air pressure 860 ~ 1060 HPa.

If the result is doubtful, should retested with the conditions below: Temp. 20±2°C, Humidity 60 ~ 70 %, Air pressure 860 ~ 1060 HPa.

※Note: As this product is not protected from foreign material entering, please make sure that any foreign materials(e.g. magnetic powder, washing solved, flux, corrosive gas)do not enter this product in your production processes. The functional degradation(e.g. SPL down)may occur if foreign material enter it.

## STANDARD TEST FIXTURE

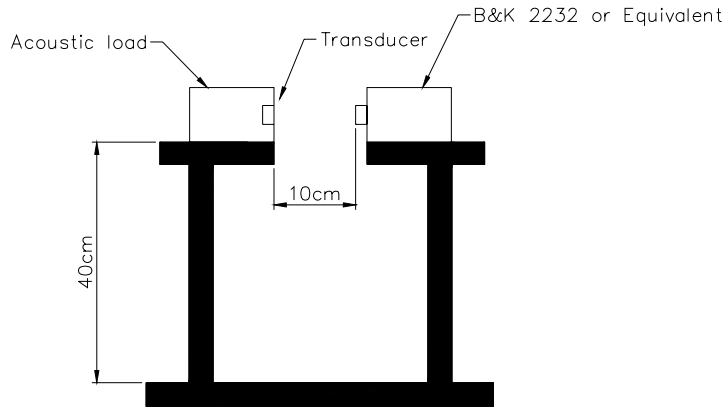

## Characteristic

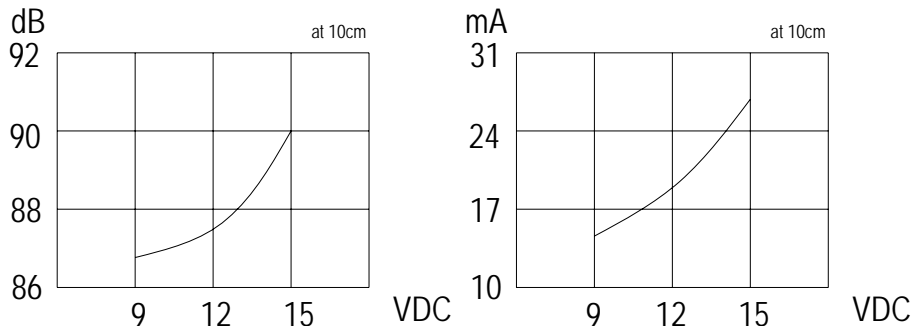

REV NO.	REVISION NOTE	APPROVAL	DATE
---------	---------------	----------	------

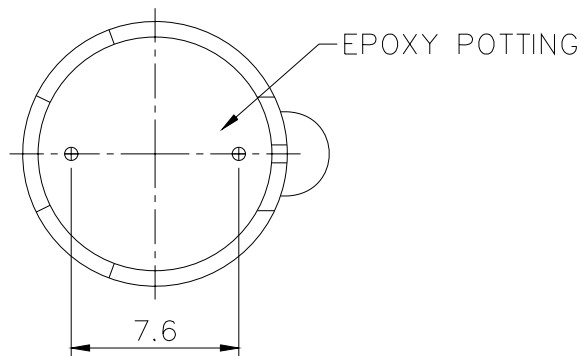
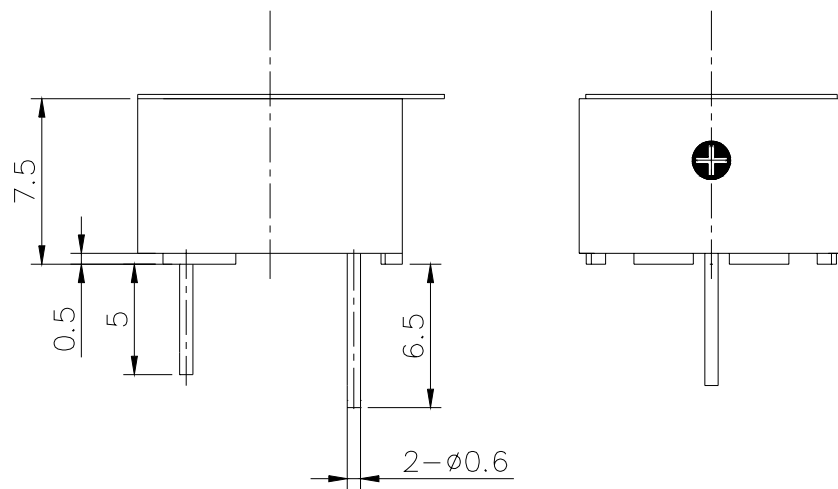
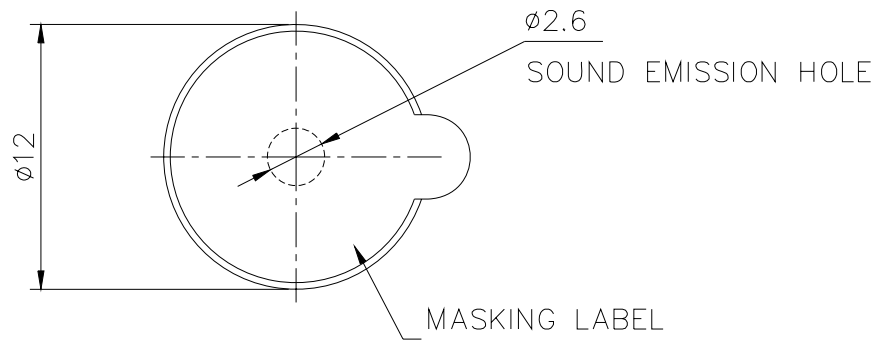

TITLE: SOUND TRANSDUCER DIMENSIONS		DRAWN: <i>Jack</i> 2003/06/21	SCALE: 3/1	SHEET: 1 of 1
PART NO. AX-1212-P3	1 REV	DESIGNED: R&D OF AAT	UNITS: mm	
DWG NO. DTT-1045		CHECKED:	TOLERANCE ± 0.5	
		APPROVAL:	UNLESS OTHERWISE SPECIFIED: ONE PLACE DECIMAL ± *** TWO PLACE DECIMAL ± *** THREE PLACE DECIMAL ± ***	
		MATERIAL: NORYL		



ADVANCED ACOUSTIC TECHNOLOGY CORPOATION

# ADVANCED ACOUSTIC TECHNOLOGY CORP.

## 苙翔科技股份有限公司

### RELIABILITY TEST

#### AX-1212-P3

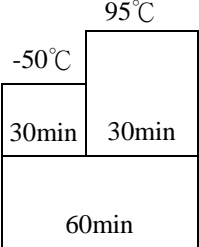
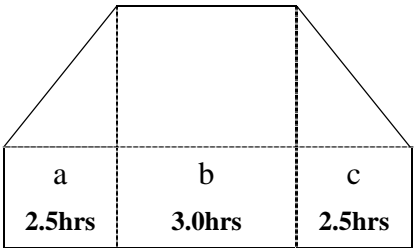
Item	Test conditions	Evaluation standard
01 <b>High temp. Storage life</b>	The part shall be capable of withstanding a storage Temperature of 95°C for 96 hours.	After the test the part shall meet specifications without Any degradation and performance except S.P.L S.P.L shall be 77dB or more.
02 <b>Low temp. Storage life</b>	The part shall be capable of withstanding a storage Temperature of -50°C for 96 hours.	
03 <b>Temp.cycle</b>	The part shall be subjected 10 cycles. One cycle shall consist of; 	
04 <b>Temp./Humidity cycle</b>	The part shall be subjected 10 cycles. One cycle shall be 8 hours and consist of;  <p style="text-align: center;">a,b:90~98%RH c :80~98%RH</p>	

# ADVANCED ACOUSTIC TECHNOLOGY CORP.

## 苙翔科技股份有限公司

### RELIABILITY TEST

#### AX-1212-P3

Item	Test conditions	Evaluation standard
05 <b>Vibration</b>	The part shall be subjected to a vibration cycle of 10Hz to 55Hz to 10Hz in a period of 1 minute. Total peak amplitude shall be 1.52mm (9.3G). The vibration test shall consist of 2 hours per plane in each three mutually perpendicular planes for a total time Of 6 hours.	After the test the part shall meet specifications without Any degradation and performance except S.P.L S.P.L shall be 77dB or more.
06 <b>Fixed drop</b>	The part shall be mounted on 100g jig(standard pc board) and dropped from a height of 152cm onto a concrete floor 5 times in each 6 planes. (a total of 30 times)	
07 <b>Free drop</b>	The part only shall be dropped from a height of 75cm onto a 40mm thick wooden board 3 times in 3 axes (X.Y.Z). (a total of 9 times).	
08 <b>Operating life</b>	1. Ordinary temperature The part shall be subjected to 1000 hours at room temperature ( $25 \pm 10^{\circ}\text{C}$ ) with 12V applied. 2. High temperature The part shall be subjected to 500 hours at $85^{\circ}\text{C}$ with 12V applied. 3. Low temperature The part shall be subjected to 500 hours at $-40^{\circ}\text{C}$ with 12V applied.	