

MESSRS.

SPECIFICATION FOR APPROVAL

承 認 書

Product	MAGNETIC BUZZER INDICATOR
Part No.	AX-1606
Customer Approval	

Approved By	Checked By	Made By



ADVANCED ACOUSTIC TECHNOLOGY CORP.

苙 翔 科 技 股 份 有 限 公 司



ISO 9001 Certified

4F, No.238, Sec. 6, Chung Shan N. Rd., Taipei, Taiwan, R.O.C.

Tel: +886-2-88665255

Fax: +886-2-88665250

E-mail: aat_mail@seed.net.tw

AX-1606

Items		Units	Specifications				Conditions
01	Rated Voltage	VDC	6				Volts D.C.
02	Operating Voltage	VDC	3 ~9				Volts D.C
03	Mean Current	mA (Max)	30				Applying rated voltage
04	Direct Current Resistance	Ohm	None				
05	Sound Output	dB (min)	85				Distance at 10cm,applying rated voltage
06	Basic Frequency	Hz	2200±300				
07	Operating Temp.	°C	-20 ~ +70				
08	Storage Temp.	°C	-30 ~ +80				
09	Dimension	mm	Φ	16	Height	14	See attached drawing.
10	Weight	Gram	2.0				
11	Terminal		Two Pins				See attached drawing.

※Standard Conditions:

Temperature 15 ~ 35°C

Humidity 25 ~ 80 %

Air pressure 860 ~ 1060 HPa.

If the result is doubtful, should retested with the conditions below:Temp. 20±2°C ,Humidity 60 ~ 70 % ,
Air pressure 860 ~ 1060 HPa.

※Note:As this product is not protected from foreign material entering,please make sure that any foreign materials(e.g. magnetic powder,washing solvend,flux,corrosive gas)do not enter this product in your production processes.The functional degradation(e.g. SPL down)may occur if foreign material enter it.

STANDARD TEST FIXTURE

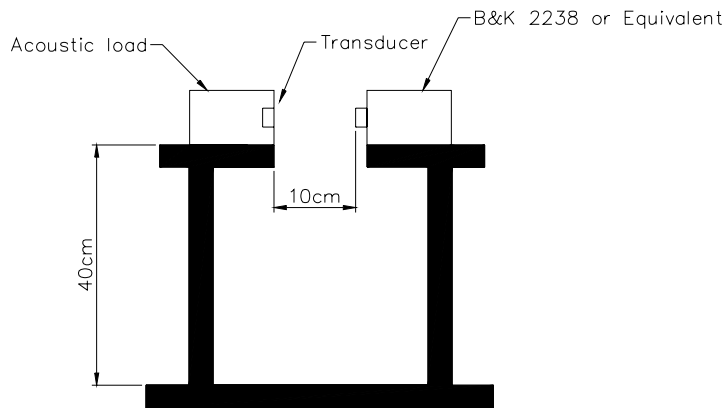

Characteristic

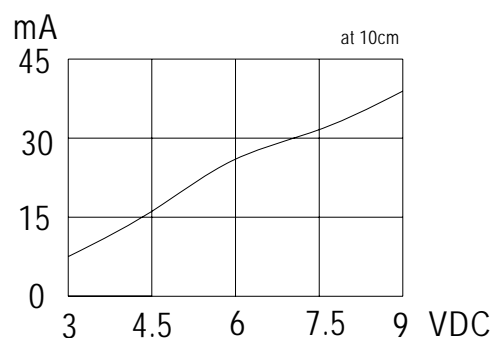
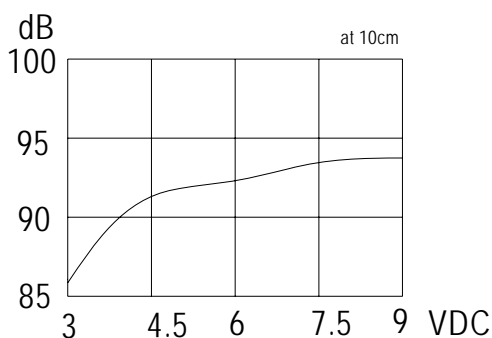

REV NO.	REVISION NOTE	APPROVAL	DATE
---------	---------------	----------	------

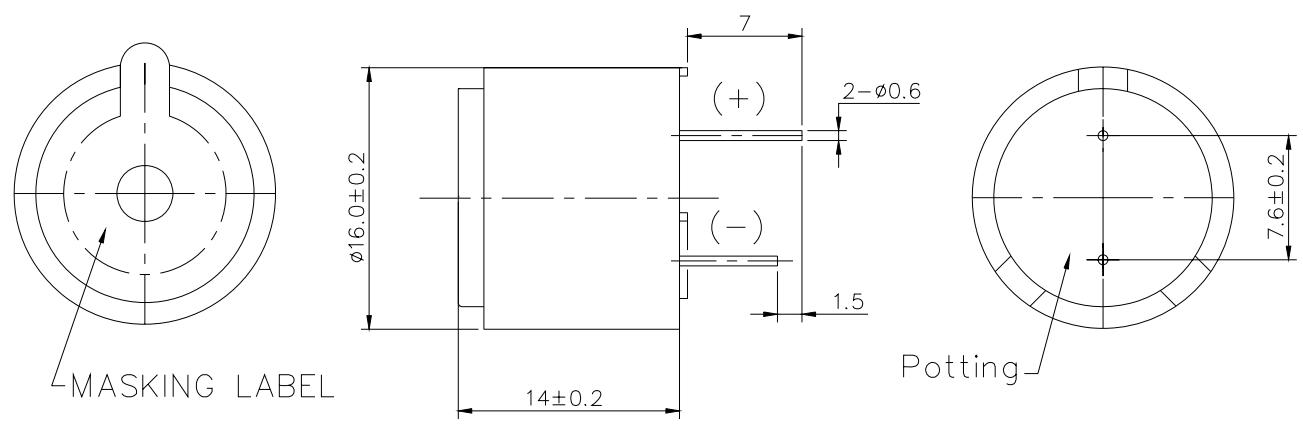

TITLE: SDUND TRANSDUCER DIMENSIONS		DRAWN: <i>JGAN</i> 11/16/2001	SCALE: 3:1	SHEET: 1:1
PART NO. AX-1606	1	DESIGNED: R & D OF AAT	UNITS: mm	
DWG NO. DTT-1079		CHECKED:	TOLERANCE ± 0.5 mm	
REV		APPROVAL:	UNLESS OTHERWISE SPECIFIED: ONE PLACE DECIMAL \pm *** TWO PLACE DECIMAL \pm *** THREE PLACE DECIMAL \pm ***	
		MATERIAL: PBT		



苙翔科技股份有限公司
 ADVANCED ACOUSTIC TECHNOLOGY CORPORATION

ADVANCED ACOUSTIC TECHNOLOGY CORP.

苙翔科技股份有限公司

RELIABILITY TEST

AX-1606

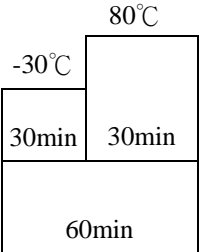
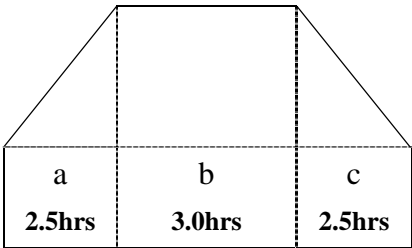
Item	Test conditions	Evaluation standard
01 High temp. Storage life	The part shall be capable of withstanding a storage Temperature of 80°C for 96 hours.	After the test the part shall meet specifications without Any degradation and performance except S.P.L S.P.L shall be 77dB or more.
02 Low temp. Storage life	The part shall be capable of withstanding a storage Temperature of -30°C for 96 hours.	
03 Temp.cycle	The part shall be subjected 10 cycles. One cycle shall consist of; 	
04 Temp./Humidity cycle	The part shall be subjected 10 cycles. One cycle shall be 8 hours and consist of;  <p style="text-align: center;">a,b:90~98%RH c :80~98%RH</p>	

ADVANCED ACOUSTIC TECHNOLOGY CORP.

苙翔科技股份有限公司

RELIABILITY TEST

AX-1606

Item	Test conditions	Evaluation standard
05 Vibration	The part shall be subjected to a vibration cycle of 10Hz to 55Hz to 10Hz in a period of 1 minute. Total peak amplitude shall be 1.52mm (9.3G). The vibration test shall consist of 2 hours per plane in each three mutually perpendicular planes for a total time Of 6 hours.	After the test the part shall meet specifications without Any degradation and performance except S.P.L S.P.L shall be 77dB or more.
06 Fixed drop	The part shall be mounted on 100g jig(standard pc board) and dropped from a height of 152cm onto a concrete floor 5 times in each 6 planes. (a total of 30 times)	
07 Free drop	The part only shall be dropped from a height of 75cm onto a 40mm thick wooden board 3 times in 3 axes (X.Y.Z). (a total of 9 times).	
08 Operating life	1. Ordinary temperature The part shall be subjected to 1000 hours at room temperature ($25 \pm 10^{\circ}\text{C}$) with 6V 2200Hz applied. 2. High temperature The part shall be subjected to 500 hours at 70°C with 6V, 2200Hz applied. 3. Low temperature The part shall be subjected to 500 hours at -20°C with 6V, 2200Hz applied.	