

MESSRS.

SPECIFICATION FOR APPROVAL

承 認 書

Product	PIEZO BUZZER ELEMENT
Part No.	AE-3116E-N-LF (RoHS)
Customer Approval	

Approved By	Checked By	Made By
工程部 王台平 AUG-30-2006	工程部 劉民祥 AUG-30-2006	工程部 許俊程 AUG-30-2006



ADVANCED ACOUSTIC TECHNOLOGY CORP.

苙 翔 科 技 股 份 有 限 公 司



ISO 9001 Certified

2F, No.207, Sec. 6, Chung Shan N. Rd., Taipei, Taiwan.

Tel: +886-2-88665255

Fax: +886-2-88665250

<http://www.aatc.com.tw>

AE-3116E-N-LF

ITEM		CONDITION
01	Type.	External -drive type sound element
02	Resonant Frequency (KHz)	1.6±0.5 at 25± 2°C , 45~60% RH
03	Input Voltage	30Vp-p Max
04	Resonant Impedance (OHM)	500 OHM Max. at 25± 2°C , 45~60% RH
05	Capacity (nF)	50±30% at 1000Hz 1Vrms
06	Plate Material	BRASS
07	Operating Temperature (°C)	-20 to +60
08	Storage Temperature (°C)	-20 to +70

Dimensions

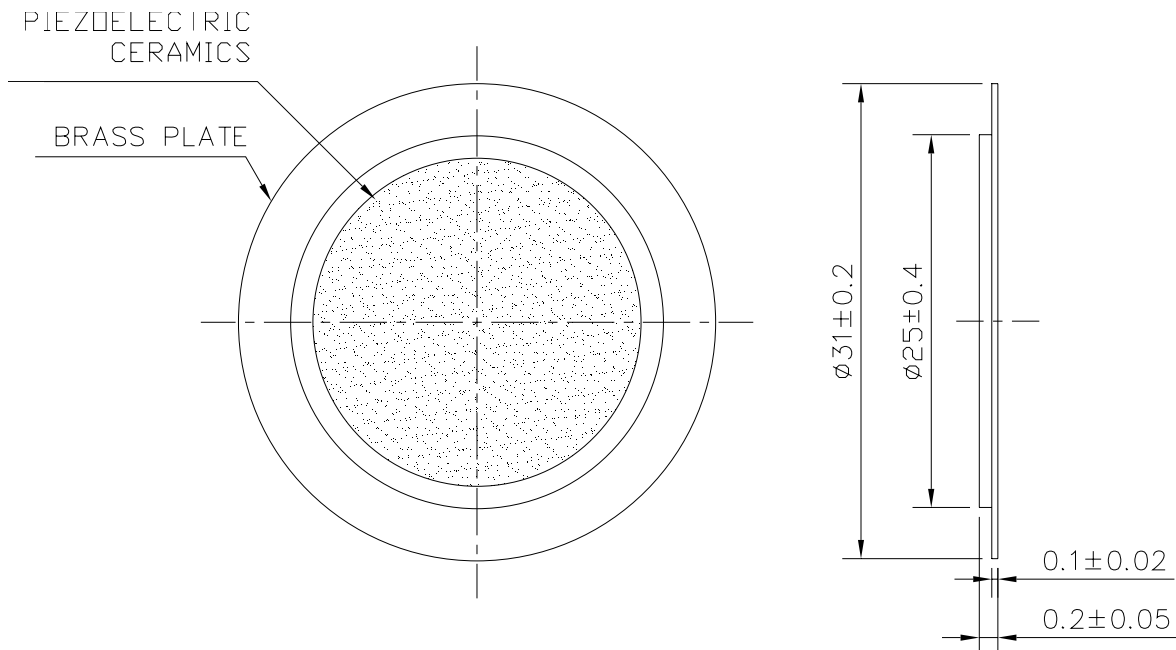

■ Piezo Ceramic Test Fixture

1. Resonant Freq. → YHP – 4192A at 1 Vrms (sweep frequency : 100Hz)
2. Resonant Imp. → YHP – 4192A at 1 Vrms (sweep frequency : 100Hz)
3. Capacitance → YHP – 4192A at 100Hz

■ Piezo Ceramic Reliability Test

No.	Item	Condition	Variance after Conditioning
01	High temperature	+70°C±2°C , 240 hrs	Resonant freq.: Initial value ±10%
02	Low temperature	-20°C±2°C , 240 hrs	
03	Humidity	+40°C±2°C , 90~95%RH , 240 hrs	
04	Thermal shock	-20°C±2°C (30min) →20°C (15min) →70°C±2°C (30min) →20°C (15min) 20 cycles	Capacitance: Initial value ±15%
05	Temp. Dependence	On place -20~ +70°C rel. 20°C	Resonant freq.: ±15% Capacitance: 0.8% / °C

Test specimens shall be kept for 4 hrs. (25°C) before measurement.