

# ***MESSRS.***

---

## **SPECIFICATION FOR APPROVAL**

## **承 認 書**

Product	PIEZO BUZZER (EXTERNAL)
Part No.	AZ-2220E-P
Customer Approval	

Approved By	Checked By	Made By



**ADVANCED ACOUSTIC TECHNOLOGY CORP.**

**苙 翔 科 技 股 份 有 限 公 司**



ISO 9001 Certified

4F, No.238, Sec. 6, Chung Shan N. Rd., Taipei, Taiwan, R.O.C.

Tel: +886-2-88665255

Fax: +886-2-88665250

E-mail: [aat\\_mail@seed.net.tw](mailto:aat_mail@seed.net.tw)

# AZ-2220E-P

	Items	Units	Specifications	Conditions
01	Rated Voltage	Vp-p	3	Square Wave
02	Operating Voltage(Max)	Vp-p	1-25	
03	Current Consumption(max)	mA	3	
04	Sound Pressure Level	dBa	70	At 10cm / 2KHz
05	Resonant Frequency	Hz	2000±500	
06	Operating Temp.	°C	-20 ~ +70	
07	Storage Temp.	°C	-30 ~ +80	
08	Capacitance	pF	19000 ± 30%	At 120Hz
09	Weight	g	3	
10	Lead wire / lead pin material	Phosphor Bronze		

Frequency Response Curve.

MODEL:AZ-2220E-P  
 X:1.9953kHz Y:83.39dB ZA:Live Curve SSR T. RMS

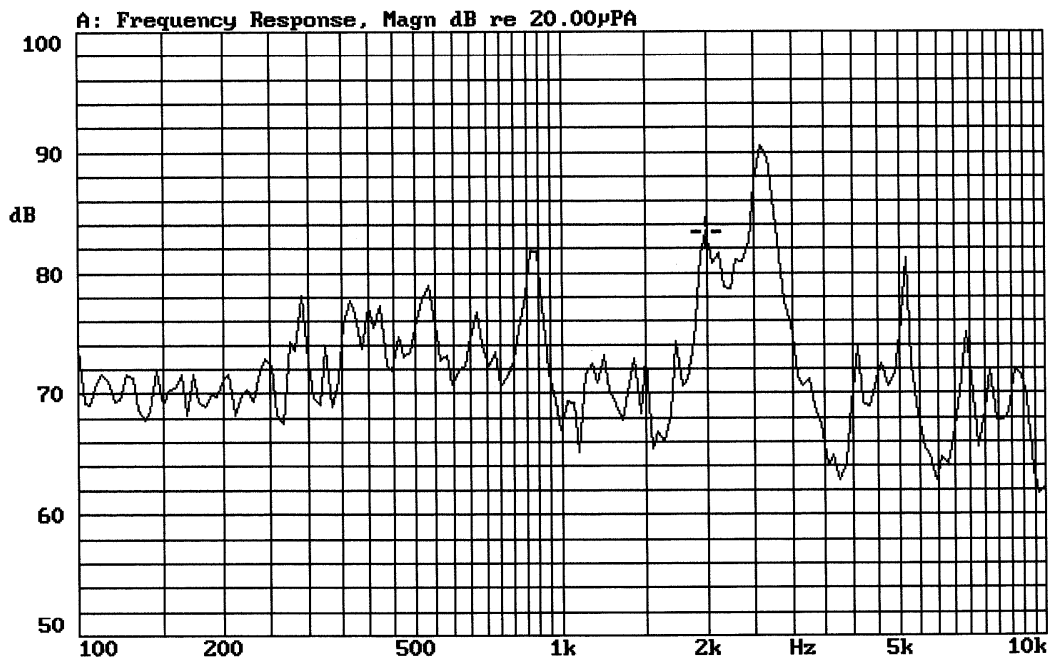

Mode: SSR



REV NO.	REVISION NOTE	APPROVAL	DATE
---------	---------------	----------	------

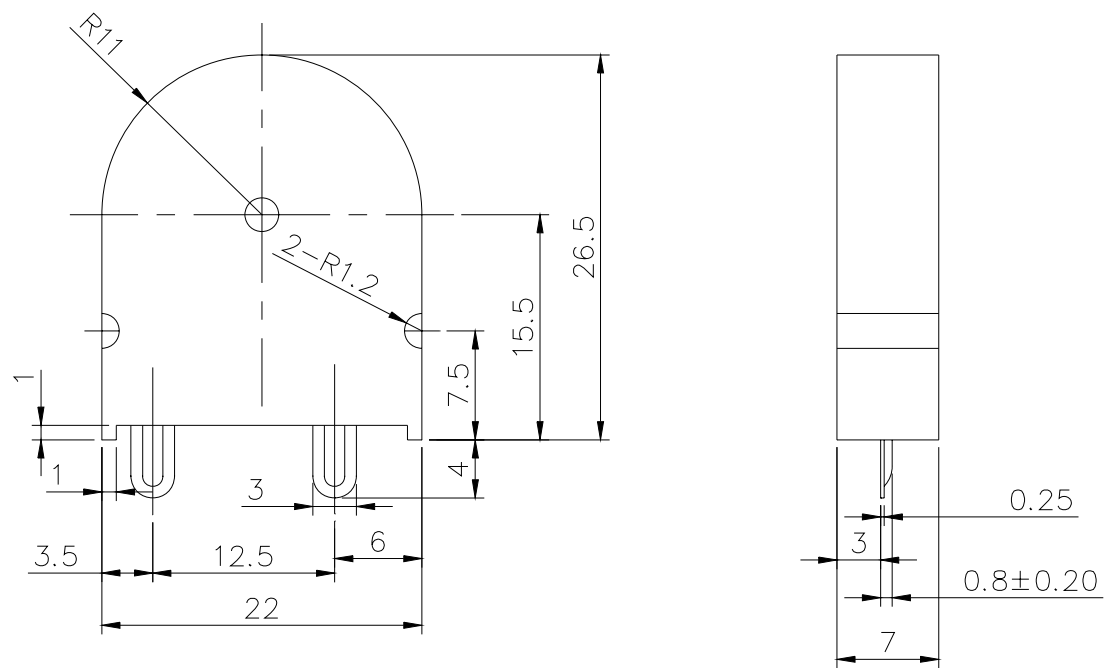

TITLE: PIEZO BUZZER EXTERNAL		DRAWN: Milton	05/09/2001	SCALE: 2:1	SHEET: 1 : 1
PART NO. AZ-2220E-P		DESIGNED: R & D OF AAT		UNITS: mm	
DWG NO. DTP-1032		CHECKED:		TOLERANCE ± 0.5	
		APPROVAL:		UNLESS OTHERWISE SPECIFIED:	
		MATERIAL: MPP0		ONE PLACE DECIMAL ± ***	
				TWO PLACE DECIMAL ± ***	
				THREE PLACE DECIMAL ± ***	



苙翔科技股份有限公司  
 ADVANCED ACOUSTIC TECHNOLOGY CORPORATION

# ADVANCED ACOUSTIC TECHNOLOGY CORP.

## 苙翔科技股份有限公司

### RELIABILITY TEST

#### AZ-2220E-P

Item	Conditions	Evaluation standard
01 Low Temp. Storage Test	A°C±2°C ,240Hr	(S.P.L)Test before numerical ±10dB *wrong (Frequency)Test before numerical ±10% (Current)Test before numerical ±10% (No crake is allowed on the part surface after Free drop test ) ● After the test ,the part shall meet the specifications without any degradation in appearance and performance
02 High Temp.Storage Test	B°C±2°C RH50% ,240Hr	
03 Temp./Humidity Storage Test	40°C±2°C , RH90-95% 240Hr	
04 Thermal Shock Test	A°C±2°C (1Hr)→ ,20°C±2°C (1Hr) B°C±2°C (1Hr)→ ,20°C±2°C (1Hr)10 cycle	
05 Vibration Test	10-55Hz/1min amplitude1.5mm,X,Y,Z,3 directions	
06 Mechanical Shock Test	+100G,Sine wave, XYZ , 3 impacts per axis	
07 Free Drop Test	The part shall be dropped freely from a height of 75 cm onto concrete 1 time in 2 axes (total 4 times )	
08 Life Burning Test	The part shall be subjected to 1000 hrs in the room temp with rated voltage applied	
09 Lead Wire / Pin Pull Test	The Part checking standard : Following supplier's Spec. Finished-part checking Standard vertical Pull i)100g MIN 0.05mm Thickness of ceramic ii)300g MIN 0.1mm ≤ Thickness of ceramic b: Horizontal Pull i)700g MIN	

Remark : "A"means Storage low temp. "B"means Storage high temp