

# *MESSRS.*

---

## SPECIFICATION FOR APPROVAL

## 承 認 書

Product	PIEZO BUZZER (SELF DRIVE)
Part No.	AZ-2434S-P-LF (RoHS)
Customer Approval	

Approved By	Checked By	Made By



**ADVANCED ACOUSTIC TECHNOLOGY CORP.**

**苙 翔 科 技 股 份 有 限 公 司**



ISO 9001 Certified

2F, No.207, Sec. 6, Chung Shan N. Rd., Taipei, Taiwan.

Tel: +886-2-88665255

Fax: +886-2-88665250

<http://www.aatc.com.tw>

# AZ-2434S-P-LF

	Items	Units	Specifications	Conditions
01	Rated Voltage	VDC	12	
02	Operating Voltage	VDC	3-20	
03	Rated Current (Max)	mA	15	
04	Min Sound Output	dB	85	at 10cm
05	Resonant Frequency	Hz	3400±500	
06	Operating Temp.	°C	-45 ~ +85	
07	Storage Temp.	°C	-50 ~ +90	
08	Weight	g	4	

Value Applying at Rated Voltage (DC)

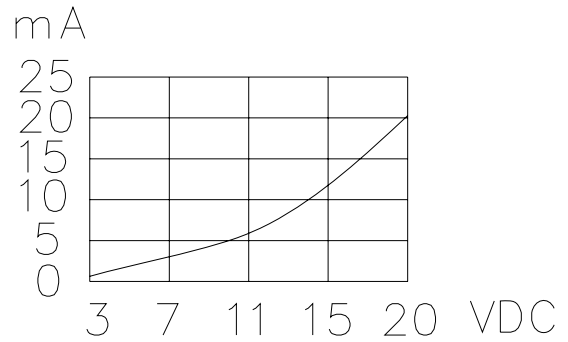
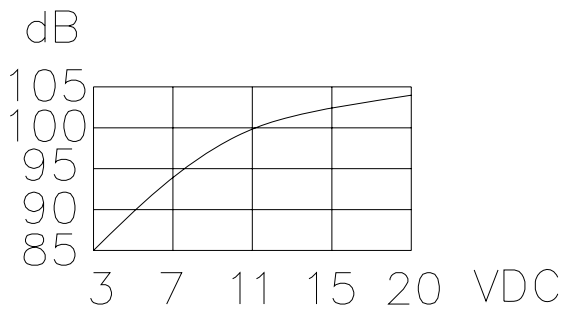

REV NO.	REVISION NOTE	APPROVAL	DATE
---------	---------------	----------	------

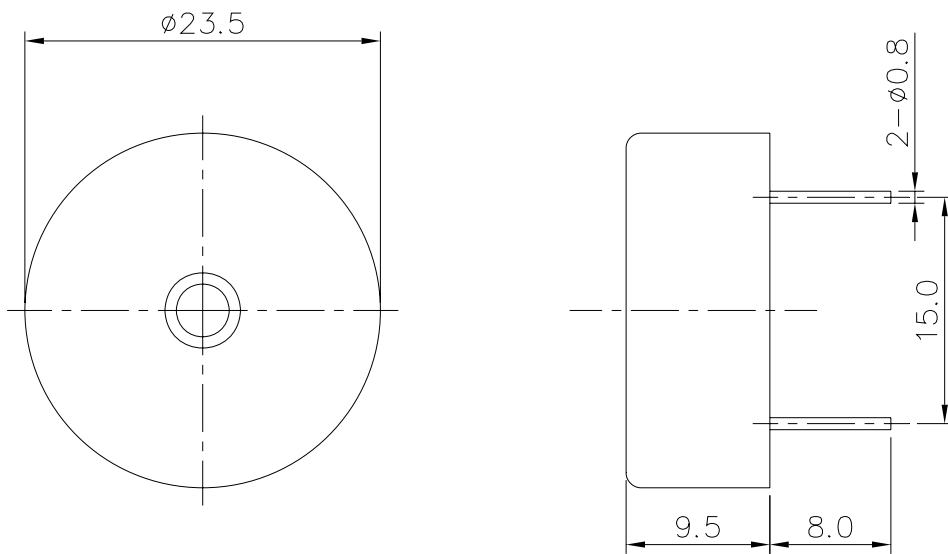

TITLE: PIEZO BUZZER	DRAWN: Milton 04/20/2001	SCALE: 2:1	SHEET: 1 : 1
PART NO. AZ-2434S-P-LF	DESIGNED: R & D OF AAT	UNITS: mm	TOLERANCE ± 0.5
DWG NO. DTP-1011	CHECKED:	UNLESS OTHERWISE SPECIFIED:	
	APPROVAL:	ONE PLACE DECIMAL ± ***	
	MATERIAL: MPPO	TWO PLACE DECIMAL ± ***	
		THREE PLACE DECIMAL ± ***	



苙翔科技股份有限公司

## RELIABILITY TEST

Item		Test conditions	Evaluation standard						
01	High temp.Storage life	The part shall be capable of withstanding a storage Temperature of 90°C for 96 hours.	After the test the part shall meet specifications without Any degradation in appearance and performance except S.P.L S.P.L shall be 74dB or more.						
02	Low temp.Storage life	The part shall be capable of withstanding a storage Temperature of -45°C for 96 hours.							
03	Temp. cycle	The part shall be subjected 5 cycles. One cycle shall consist of; <table border="1" style="margin-left: auto; margin-right: auto;"> <tr> <td style="text-align: center;">-45°C</td> <td style="text-align: center;">90°C</td> </tr> <tr> <td style="text-align: center;">30min</td> <td style="text-align: center;">30min</td> </tr> <tr> <td colspan="2" style="text-align: center;">60min</td> </tr> </table>		-45°C	90°C	30min	30min	60min	
-45°C	90°C								
30min	30min								
60min									
04	Temp./Humidity cycle	The part shall be subjected with 90~95% R.H at +40°C for 96 hours.							
05	Free drop	The part only shall be dropped from a height of 75cm onto a 40mm thick wooden board 3 times in 3 axes (X.Y.Z). (a total of 9 times).							
06	Lead Strength	Pull lead with a force of 10N, on the direction of the lead axis for 10 :10±1 sec							
07	Vibration	The part shall be subjected to a vibration cycle of 10Hz to 55Hz to 10Hz in a period of 1 minute. Total peak amplitude shall be 1.52mm (9.3G). The vibration test shall consist of 2 hours per plane in each three mutually perpendicular planes for a total time of 6 hours.							

## SOLDERING CONDITION

Recommend using constant branding iron in **30W**, and in temperature range **350±10°C**.  
Soldering time **2 seconds**.