

MESSRS.

SPECIFICATION FOR APPROVAL

承 認 書

Product	PIEZO BUZZER (SELF DRIVE)
Part No.	AZ-2434S-PD
Customer Approval	

Approved By	Checked By	Made By
工程部 王台平 MAY-26-2006	工程部 劉民祥 MAY-26-2006	工程部 許俊程 MAY-26-2006



ADVANCED ACOUSTIC TECHNOLOGY CORP.

苙 翔 科 技 股 份 有 限 公 司



ISO 9001 Certified

2F, No.207, Sec. 6, Chung Shan N. Rd., Taipei, Taiwan.

Tel: +886-2-88665255

Fax: +886-2-88665250

<http://www.aatc.com.tw>

AZ-2434S-PD

Items		Units	Specifications	Conditions
01	Rated Voltage	VDC	12	
02	Operating Voltage	VDC	3-20	
03	Rated Current (Max)	mA	10	
04	Min Sound Output	dBA	95	at 10cm
05	Resonant Frequency	Hz	3400±500	
06	Operating Temp.	°C	-20 ~ +80	
07	Storage Temp.	°C	-30 ~ +90	
08	Tone Nature	Single		
09	Weight	g	4	
10	Lead Pin Material	Beryllium Bronze		

Frequency Response Curve

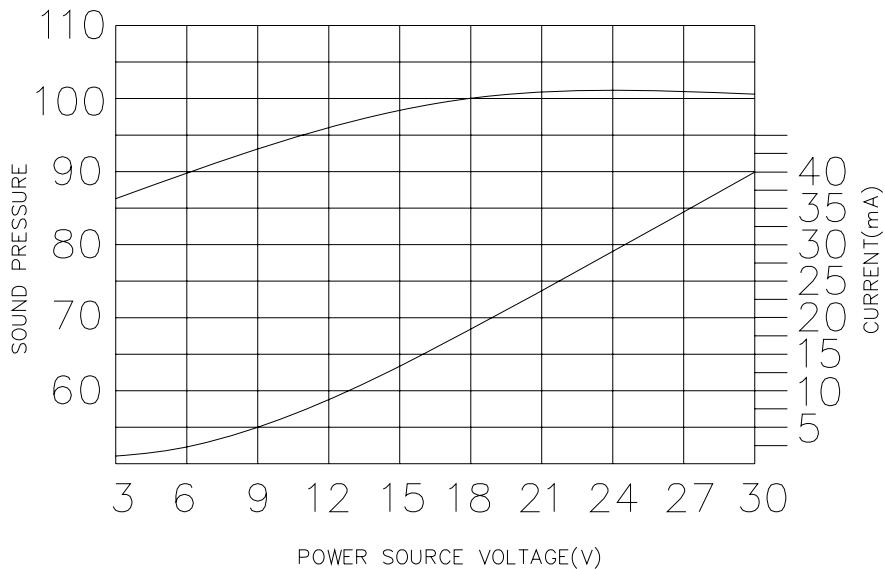

REV NO.

REVISION NOTE

APPROVAL

DATE

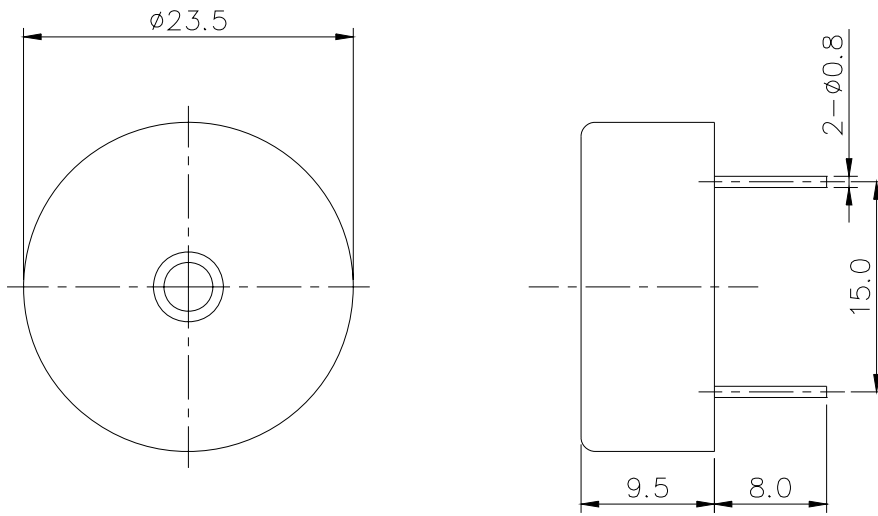

TITLE: <i>PIEZO BUZZER</i>		DRAWN: <i>Milton</i> 04/20/2001	SCALE: 2:1	SHEET: 1 : 1
PART NO. <i>AZ-2434S-PD</i>	1	DESIGNED: <i>R & D OF AAT</i>	UNITS: <i>mm</i>	
DWG NO. <i>DTP-1011</i>		CHECKED:	TOLERANCE ± 0.5	
	REV	APPROVAL:	UNLESS OTHERWISE SPECIFIED:	
		MATERIAL: <i>MPP0</i>	ONE PLACE DECIMAL \pm ***	
			TWO PLACE DECIMAL \pm ***	
			THREE PLACE DECIMAL \pm ***	



苙翔科技股份有限公可
 ADVANCED ACOUSTIC TECHNOLOGY CORPORATION

ADVANCED ACOUSTIC TECHNOLOGY CORP.

荳翔科技股份有限公司

RELIABILITY TEST

AZ-2434S-PD

Item	Conditions	Evaluation standard
01 Low Temp. Storage Test	A°C±2°C ,240Hr	(S.P.L)Test before numerical ±10dB *wrong (Frequency)Test before numerical ±10% (Current)Test before numerical ±10% (No crake is allowed on the part surface after Free drop test) ● After the test ,the part shall meet the specifications without any degradation in appearance and performance
02 High Temp.Storage Test	B°C±2°C RH50% ,240Hr	
03 Temp./Humidity Storage Test	40°C±2°C , RH90-95% 240Hr	
04 Thermal Shock Test	A°C±2°C (1Hr)→ ,20°C±2°C (1Hr) B°C±2°C (1Hr)→ ,20°C±2°C (1Hr)10 cycle	
05 Vibration Test	10-55Hz/1min amplitude1.5mm,X,Y,Z,3 directions	
06 Mechanical Shock Test	+100G,Sine wave, XYZ , 3 impacts per axis	
07 Free Drop Test	The part shall be dropped freely from a height of 75 cm onto concrete 1 time in 2 axes (total 4 times)	
08 Life Burning Test	The part shall be subjected to 1000 hrs in the room temp with rated voltage applied	
09 Lead Wire / Pin Pull Test	The Part checking standard : Following supplier's Spec. Finished-part checking Standard vertical Pull i)100g MIN 0.05mm Thickness of ceramic ii)300g MIN 0.1mm ≤ Thickness of ceramic b: Horizontal Pull i)700g MIN	

Remark : "A"means Storage low temp. "B"means Storage high temp