

MESSRS.

SPECIFICATION FOR APPROVAL

承 認 書

Product	DYNAMIC RECEIVER
Part No.	AR-1532DA-19W
Customer Approval	

Approved By	Checked By	Made By
工程 部 王台平 SEP-13-2004	工程 部 劉民祥 SEP-13-2004	工程 部 許俊程 SEP-13-2004



ADVANCED ACOUSTIC TECHNOLOGY CORP.

苙 翔 科 技 股 份 有 限 公 司



ISO 9001 Certified

2F, No.207, Sec. 6, Chung Shan N. Rd., Taipei, Taiwan, R.O.C.

TEL: +886-2-88665255

FAX: +886-2-88665250

E-MAIL: aat_mail@seed.net.tw

1. SPECIFICATION

ITEMS.		SPECIFICATIONS
01	Type	Dynamic 15mm receiver unit
02	Sensitivity (S.P.L)	115dB \pm 3 dB at 1kHz 180mV with IEC 318 coupler
03	Impedance.	32 Ohm \pm 15% at 1KHz
04	Magnet Field Intensity.	Axial – dB , Radial –dB at 1KHz
05	Nominal Input Power	1 mW
06	Max. Input Power.	Must be normal at a white noise , 2mW for 1 minute.
07	Total Harmonics Distortion	Max 8 % at 1K Hz.
08	Operation temperature	-20°C to +60°C
09	Storage temperature	-30°C to +70°C
10	Weight.	1.3g \pm 0.3g

2. MEASURING METHOD

2-1. Test Condition

STANDARD

Temperature : 15 ~ 35°C

Relative humidity : 45% ~ 85%,

Atmospheric pressure : 860mbar to 1060mbar.

JUDGEMENT

Temperature : 20 \pm 3°C

Relative humidity : 60% ~ 70%,

Atmospheric pressure : 860mbar to 1060mbar

2-2. Standard Test Fixture

Input signal : 180mV

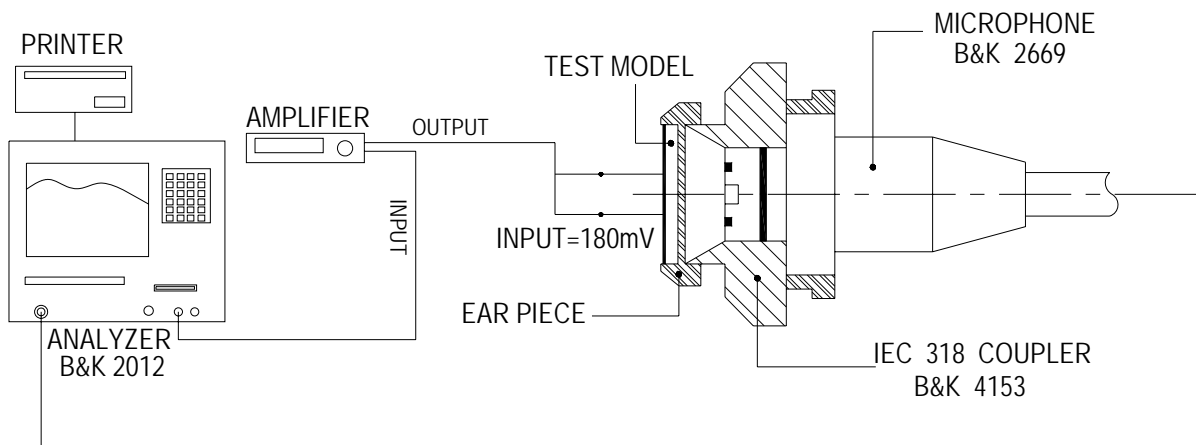

2.3 2Frequency Response Curve

X:1.0000kHz *Y:112.56dB EA:Live Curve SSR Fund.

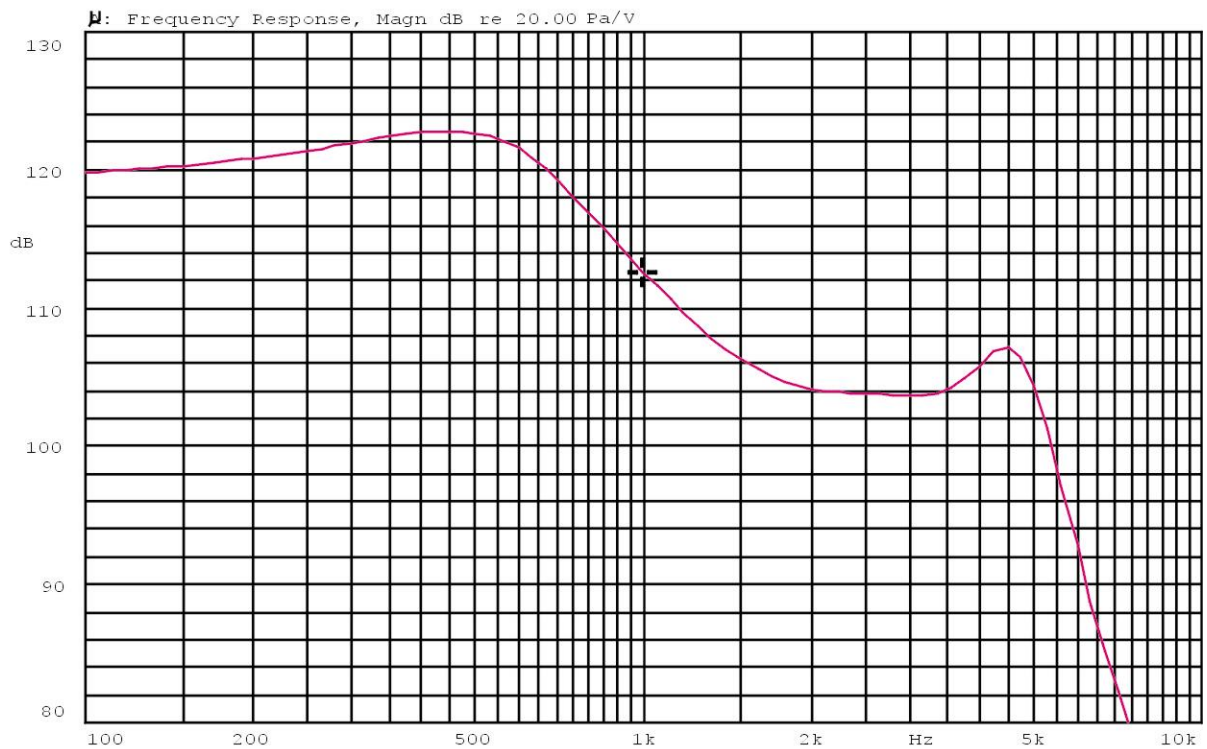

Mode: Receiver



REV NO.	REVISION NOTE	APPROVAL	DATE
---------	---------------	----------	------

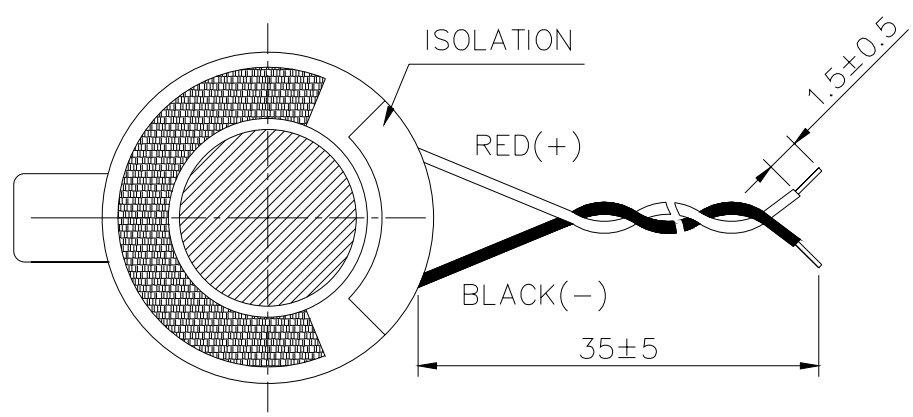

WIRE : UL1571 AWG32

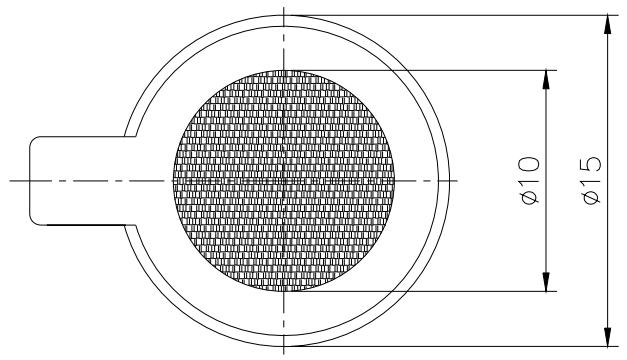
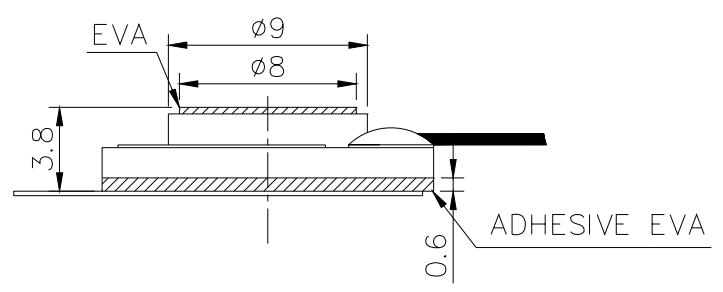

TITLE: DYNAMIC RECEIVER		DRAWN: JOYEN 09/13/2004	SCALE: 3:1	SHEET: 1 of 1
PART NO. AR-1532DA-19W		DESIGNED: R & D OF AAT	UNITS: mm	
DWG NO. DTR-1084	1 REV	CHECKED:	TOLERANCE ± 0.2	
		APPROVAL:	UNLESS OTHERWISE SPECIFIED: ONE PLACE DECIMAL ± ***	
		MATERIAL: *****	TWO PLACE DECIMAL ± *** THREE PLACE DECIMAL ± ***	



苙翔科技股份有限公司
ADVANCED ACOUSTIC TECHNOLOGY CORPORATION

4. RELIABILITY TESTS

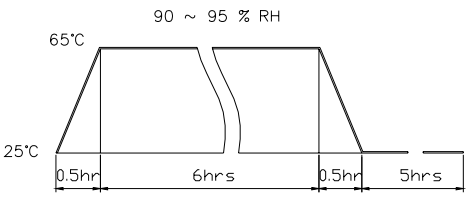
ITEMS.		SPECIFICATIONS
01	High temp. Test	Keep 96 hours at $+70^{\circ}\text{C} \pm 3^{\circ}\text{C}$ and leave 3 hours in normal temperature and then check
02	Low temp. Test	Keep 96 hours at $-20^{\circ}\text{C} \pm 3^{\circ}\text{C}$ and leave 3 hours in normal temperature and then check
03	Humidity test	Keep 96 hours at $+40^{\circ}\text{C} \pm 3^{\circ}\text{C}$ relative humidity 90% and leave 3 hours in normal temperature and then checked.
04	Temp./humidity cycle	<p>The part shall be subjected 5 cycles. One cycle shall be 12 hours and consist of;</p>  <p style="text-align: center;"> 65°C $90 \sim 95 \% \text{ RH}$ 25°C 0.5hr 6hrs 0.5hr 5hrs </p>
05	Thermal Cycle Test.	Low temperature: $-40^{\circ}\text{C} \pm 3^{\circ}\text{C}$, temperature: $+70^{\circ}\text{C} \pm 3^{\circ}\text{C}$, cycle: 1 hour/cycle each, and then keep 5 cycles in a room.
06	Vibration	10~200~10Hz Sin-Wave Sweep 15min. 5G(Constant) X,Y, Z 3 direction. 2 hours each, total 6 hours.
07	Fix Drop test	Fix on Jig. then drop from 152cm height to the concrete floor X,Y, Z 6 direction. 5 times each, total 30 times.
08	Free Drop test	Free drop from 100cm height to the concrete floor X,y, z 6 direction. 1 times each, total 6 times.
09	DC Voltage test	DC 0.25V for 1 hour.
10	Load test	Rated power white noise is applied for 96 hours
11	Max Power test	Max Power 1 minute on – 1 minute off 10 cycles.



Test Report

ADVANCED ACOUSTIC TECHNOLOGY CORPORATION Report No. : CE/2004/91205
2F, NO. 207, SEC. 6, CHUNG SHAN N. RD., SHIH-LIN, Date : 2004/09/09
TAIPEI, TAIWAN, R. O. C. Page : 1 of 1

The following merchandise was (were) submitted and identified by the client as :

Type of Product : RECEIVER
Style/Item No : FRAME
Sample Received : 2004/09/07
Testing Date : 2004/09/07 TO 2004/09/09

Test Result

PART NAME NO.1 : SILVER-BLUE COLORED METAL

Test Item (s):	Unit	Method	MDL	Result				
				No.1				
Chromium VI (Cr+6)	ppm	As per US EPA 7196A and US EPA 3060A.	2	N.D.				
Cadmium (Cd)	ppm	ICP-AES after as per EN 1122, method B:2001 or other acid digestion.	2	N.D.				
Mercury (Hg)	ppm	ICP-AES after as per US EPA 3052 or other acid digestion.	2	N.D.				
Lead (Pb)	ppm	ICP-AES after as per US EPA 3050B or other acid digestion.	2	35.7				

NOTE: (1) N.D. = Not detected (<MDL)
(2) ppm = mg/kg
(3) MDL = Method Detection Limit

Daniel Yen, M.P., Operation Manager
Signed for and on behalf of
SGS TAIWAN LTD.



Test Report

ADVANCED ACOUSTIC TECHNOLOGY CORPORATION Report No. : CE/2004/91206
2F, NO. 207, SEC. 6, CHUNG SHAN N. RD., SHIH-LIN, Date : 2004/09/09
TAIPEI, TAIWAN, R. O. C. Page : 1 of 2

The following merchandise was (were) submitted and identified by the client as :

Type of Product : RECEIVER
Style/Item No : PCB
Sample Received : 2004/09/07
Testing Date : 2004/09/07 TO 2004/09/09

=====

Test Result : - Please see the next page -

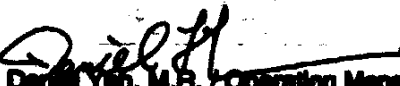
Daniel Yen, M.P. / Operation Manager
Signed for and on behalf of
SGS TAIWAN LTD.



Test Report

No.: SZTYR030930828/LP

Date: SEP 09, 2003

Page 1 of 1

LONSID ELECTRIC CO., LTD.
INDUSTRIAL ZONE OF WEN ZHOU BRIDGE,
YUEQING CITY, ZHE JIANG, CHINA

Report on the submitted sample said to be AUM STYLE: 1007, 1015, 1028, 1032, 1061, 1095, 1571, 1569, 2468, 1617, 1672, 1618, 2651, 2678

Item No. : STYLE UL 1015
Supplier / Manufacturer : LONSID ELECTRIC CO., LTD.
Country of Origin : CHINA
Sample Receiving Date : SEP 05, 2003
Testing Period : SEP 05, 2003 TO SEP 09, 2003

Test Requested : As specified by client, for compliance with the European Standard on Safety of Toys, EN71 Part 3: 1994 (including amendment A1: 2000) - Migration of Certain Elements.

Test Method : As specified in the EN71 part 3: 1994 (including amendment A1: 2000).
Analysis was performed by Inductively Coupled Plasma Atomic Emission Spectrometer.

Results

	Brown plastics w/ black printing (Wire)	Limit
Soluble Lead (Pb)	< 5	90 mg/kg
Soluble Antimony (Sb)	< 5	80 mg/kg
Soluble Arsenic (As)	< 2.5	75 mg/kg
Soluble Barium (Ba)	< 10	1000 mg/kg
Soluble Cadmium (Cd)	< 5	75 mg/kg
Soluble Chromium (Cr)	< 5	80 mg/kg
Soluble Mercury (Hg)	< 6.7	60 mg/kg
Soluble Selenium (Se)	< 10	500 mg/kg

Note: - < = Less than
- Results shown are of the adjusted analytical results.

Conclusion : When tested as specified, the submitted sample comply with the stated requirement of the European Standard EN71 Part 3: 1994 (including amendment A1: 2000)

*** End of Report ***

Signed for and on behalf of
SGS-CSTC Ltd.

Zhang Yanzheng, Helen
Sr. Section Head

This Test Report is issued by the Company subject to its General Conditions of Service printed overleaf. Attention is drawn to the limitations of liability, indemnification and jurisdictional issues defined therein. The results shown in this test report refer only to the sample(s) tested unless otherwise stated. This Test Report cannot be reproduced, except in full, without prior written permission of the Company.

SZL 190287