

MESSRS

SPECIFICATION FOR APPROVAL

承 認 書

Product	DYNAMIC SPEAKER
Part No.	AK-1608DA-6-LF (RoHS)
Customer Approval	

Approved By	Checked By	Made By
工程部 王台平 FEB-22-2005	工程部 劉民祥 FEB-22-2005	工程部 許俊程 FEB-22-2005



ADVANCED ACOUSTIC TECHNOLOGY CORP.

苙 翔 科 技 股 份 有 限 公 司



ISO 9001 Certified

2F, No.207, Sec. 6, Chung Shan N. Rd., Taipei, Taiwan.

Tel: +886-2-88665255

Fax: +886-2-88665250

<http://www.aatc.com.tw>

File Name:

1. SPECIFICATION

AK-1608DA-6-LF

ITEM		SPECIFICATIONS	
01	Type	Dynamic speaker	
02	Dimension	External diameter 16 mm	
03	Rated Input Power	0.5W	
04	Impedance	8 ohm \pm 15% at 2000Hz	
05	Resonance Frequency (Fo)	920 Hz \pm 20% at Fo, 1V	
06	Sensitivity (S.P.L.)	72dB(W/m) \pm 3 dB	at AVE 1.2– 2.0 KHz.
		88dB (0.5W/0.1m) \pm 3 dB	
07	Frequency Range	Fo – 20KHz	
08	Distortion	Less than 5 % at 2000Hz,0.5W	
09	Max. Input Power	Must be normal at 0.8W white noise for 1 minute.	
10	Voice Coil	Diameter 7.4mm	
11	Magnet	Rare earth permanent (Nd-Fe-B) magnet Φ 6.5 x 1.0 mm	
12	Weight	1.8g \pm 0.3g	
13	Appearance	Should not exist any obstacle to be harmful to normal operation; damages, cracks, rusts and distortions, etc.	
14	Operation Test	Must be normal at program source – 0.5W	
15	Buzz, Rattle, etc.	Should not be audible at 2.0V sine Wave between Fo to 20KHz	
16	Polarity	When positive voltage is applied to the terminal marked (+), diaphragm should move to the front.	
17	Terminal Strength	Capable of withstand 1kg load for 30 seconds without resulting in any damage or rejection.	
18	Temperature	Operating temperature: -20°C to +60°C	
		Storage temperature: -30°C to +70°C	

2. MEASURING METHOD

2-1 .Test Condition

STANDARD

Temperature : 15 ~ 35°C

Relative humidity : 45% ~ 85%,

Atmospheric pressure : 860mbar to 1060mbar.

JUDGEMENT

Temperature : 20±3°C

Relative humidity : 60% ~ 70%,

Atmospheric pressure : 860mbar to 1060mbar

2-2 . Standard Test Fixture

1.Input Power : 0.5W(2.0V)

2.Zero Level : -dB

3.Mode : SPEAKER

4.potentiometer Range : 50dB

5.Sweep Time : 0.5sec

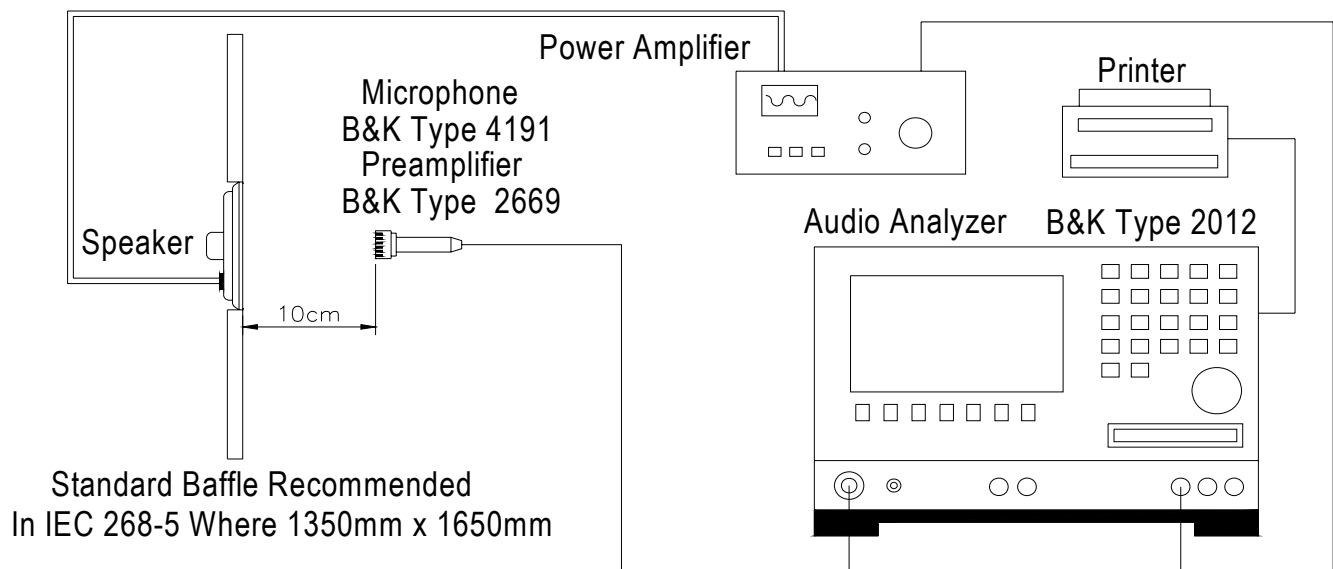

2-3. Frequency Response Curve

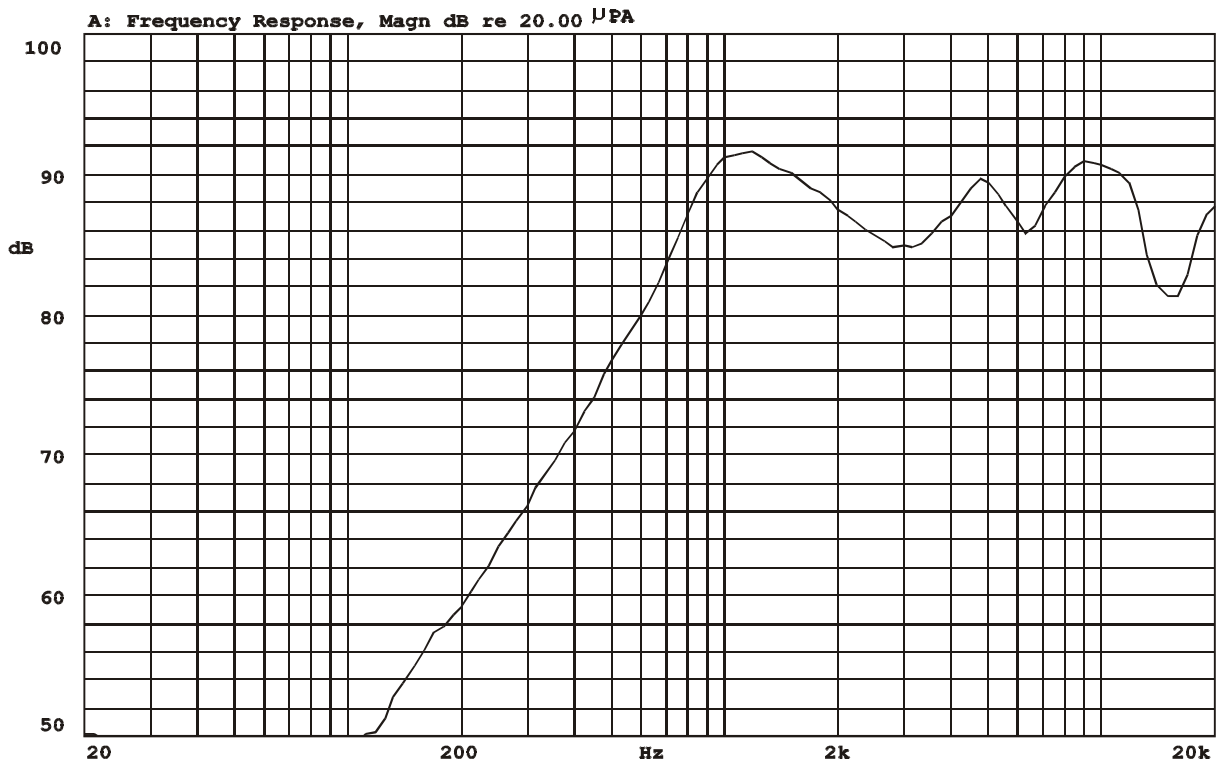

Mode: SPEAKER



2-4. Impedance Curve

IMPEDANCE MEASUREMENTS: Measurement of Impedance $Z(j\omega)$
ZA: Live Curve Impedance Ω

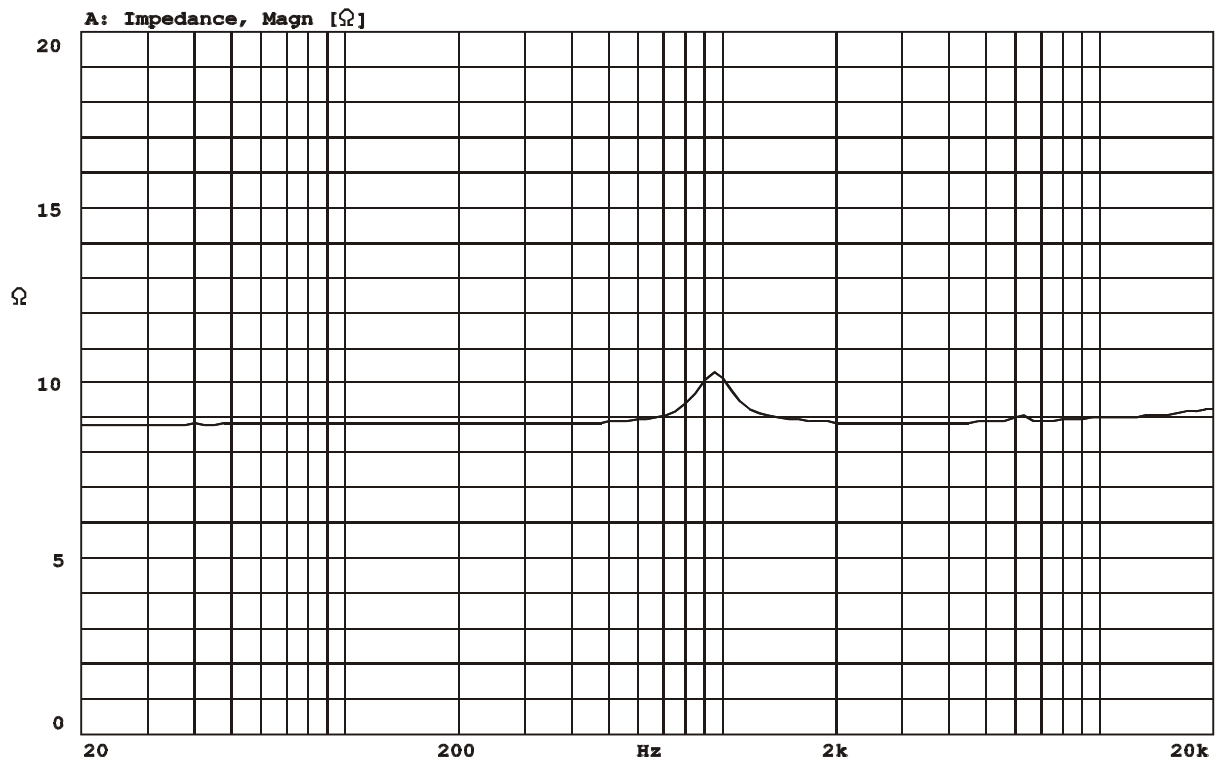

Mode: $Z(j\omega)$



REV NO.	REVISION NOTE	APPROVAL	DATE
---------	---------------	----------	------

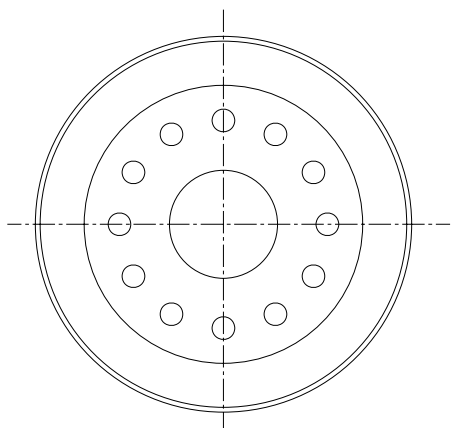
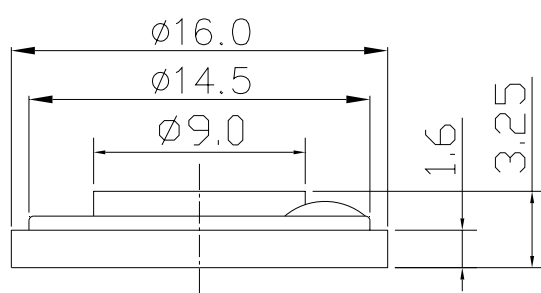
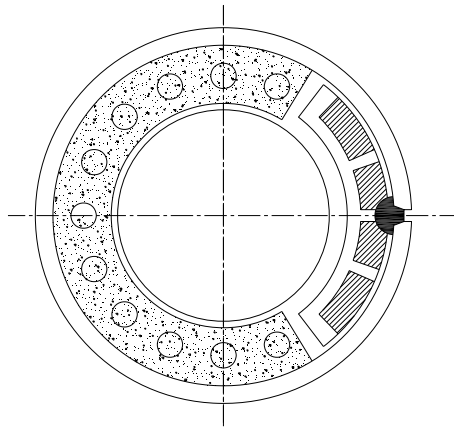

TITLE: DYNAMIC SPEAKER		DRAWN: Ellen	2005/07/19	SCALE: 2:1	SHEET: 1 of 1
PART NO. AK-1608DA-6-LF		DESIGNED: R&D OF AAT	UNITS: mm		
DWG NO. DSE-1261		CHECKED:	TOLERANCE ± 0.3		
		APPROVAL:	UNLESS OTHERWISE SPECIFIED: ONE PLACE DECIMAL ± *** TWO PLACE DECIMAL ± *** THREE PLACE DECIMAL ± ***		
		REV 1	MATERIAL: *****		



ADVANCED ACOUSTIC TECHNOLOGY CORPORATION

3. RELIABILITY TESTS

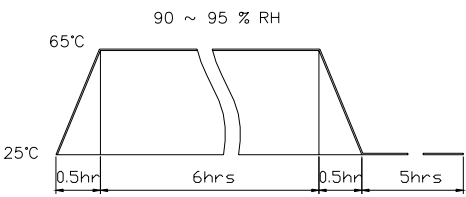
Items.		Specifications
01	High temp. Test	Keep 96 hours at $+70^{\circ}\text{C}\pm 3^{\circ}\text{C}$ and leave 3 hours in normal temperature and then check
02	Low temp. Test	Keep 96 hours at $-20^{\circ}\text{C}\pm 3^{\circ}\text{C}$ and leave 3 hours in normal temperature and then check
03	Humidity test	Keep 96 hours at $+60^{\circ}\text{C}\pm 3^{\circ}\text{C}$ relative humidity 95% and leave 3 hours in normal temperature and then checked.
04	Temp./Humidity cycle	<p>The part shall be subjected 5 cycles. One cycle shall be 12 hours and consist of;</p> 
05	Thermal cycle test.	Low temperature: $-30^{\circ}\text{C}\pm 3^{\circ}\text{C}$, temperature: $+70^{\circ}\text{C}\pm 3^{\circ}\text{C}$, cycle: 1 hour/cycle each, and then keep 5 cycles in a room.
06	Vibration	10~200~10Hz sin-wave sweep 15min. 5G(constant) X,Y, Z 3 direction. 2 hours each, total 6 hours.
07	Fix drop test	Fix on jig. Then drop from 152cm height to the concrete floor X,y, z 6 direction. 5 times each, total 30 times.
08	Free drop test	Free drop from 100cm height to the concrete floor X,y, z 6 direction. 1 times each, total 6 times.
09	Load test	Rated Power white noise is applied for 96 hours
10	Max Power test	Max power 1 min on - 2 min off 10 cycles.
11	Terminal strength test	Capable of withstand 1kg load for 30 seconds without resulting in any damage or rejection.
<p>Criterion :</p> <p>After these test , the change of S.P.L shall be within ± 3 dB .</p>		