

# MESSRS.

## SPECIFICATION FOR APPROVAL

### 承 認 書

Product Name	Dynamic Speaker	
P/N @ AATC	<b>AK – 5708BC-16</b>	<b>(RoHS)</b>
Approved @ AATC	Checked @ AATC	Made @ AATC

Customer Approval Result	
--------------------------	--



**Advanced Acoustic Technology Corporation**  
**苙 翔 科 技 // 常州苙翔电子有限公司**



ISO 9001 Certified

ISO 14001 Certified [http:// www.aatc.com.tw](http://www.aatc.com.tw) [www.aatc.com.cn](http://www.aatc.com.cn)

RoHS – Compliant

Head Office / 2F, No.207, Sec. 6, Chung Shan N. Rd., Taipei, Taiwan Province  
Tel: +886-2-8866-5255 Fax: +886-2-8866-5250

EDITION:1.1

## AK-5708BC-16

01	Type	Dynamic speaker	
02	Dimension	External diameter 57 mm	
03	Rated Input Power	0.5 W	
04	Impedance	8 ohm $\pm$ 15% at 1000Hz	
05	Resonance Frequency (Fo)	500 Hz $\pm$ 20% at Fo, 1V	
06	Sensitivity (S.P.L.)	84dB(1W/1m) $\pm$ 3 dB	at AVE 0.8K,1.0K,1.2K,1.5K(Hz).
07	Frequency Range	Fo – 4000Hz	
08	Distortion	Less than 10 % at 1000Hz 0.5 W	
09	Max. Input Power	Must be normal at 0.5W white noise for 1 minute.	
10	Voice Coil	Diameter 13.2 mm	
11	Magnet	Rare earth permanent (Nd-Fe-B) magnet $\Phi$ 12.5 x 2.5mm	
12	Weight	20 g $\pm$ 5%	
13	Appearance	Should not exist any obstacle to be harmful to normal operation; damages, cracks, rusts and distortions, etc.	
14	Operation Test	Must be normal at program source –0.5W	
15	Buzz, Rattle, etc.	Should not be audible at 2.0V sine Wave between Fo to 20KHz	
16	Polarity	When positive voltage is applied to the terminal marked (+), diaphragm should move to the front.	
17	Terminal Strength	Capable of withstand 1kg load for 30 seconds without resulting in any damage or rejection.	
18	Load Test	0.5 W white noise is applied for 96 hours and satisfy the test listed on item 05,06,13,15	
19	High Temp. Test	Keep 96 hours at +70°C $\pm$ 3°C and leave 3 hours in normal temperature and then check	
20	Low Temp. Test	Keep 96 hours at -20°C $\pm$ 3°C and leave 3 hours in normal temperature and then check	
21	Humidity Test	Keep 96 hours at + 60°C $\pm$ 3°C relative humidity 95% and leave 3 hours in normal temperature and then checked.	
22	Drop Test	Drop the speakers contained in normal box onto the board 20mm thick 10 times from the height of 0.75m and then should satisfy the test listed on item 13 and 15	

## Measurement Condition

Test and measurement will be carried out under normal condition of temperature

within  $5^{\circ}\text{C}$  to  $35^{\circ}\text{C}$  ,relative humidity within 45% to 85% and air pressure of 860mbar to 1060mbar.

Should uncertainly arise in data obtained from the above atmosphere, control of temperature

At  $20^{\circ}\text{C} \pm 2^{\circ}\text{C}$  and relative humidity within 60% and 70%, with air pressure remaining unchanged,

To be enforced.

1.Microphone : B&K 4191

2.Standard Baffle : In IEC 268-5 Where 1350mm x 1650mm

3.Testing Distance : 0.1m

4.Zero Level : -dB

5.Mode : SPEAKER

6.Input Power : 0.5W

7.potentiometer Range : 50dB

8.Sweep Time : 0.5sec

## Standard test condition of speaker

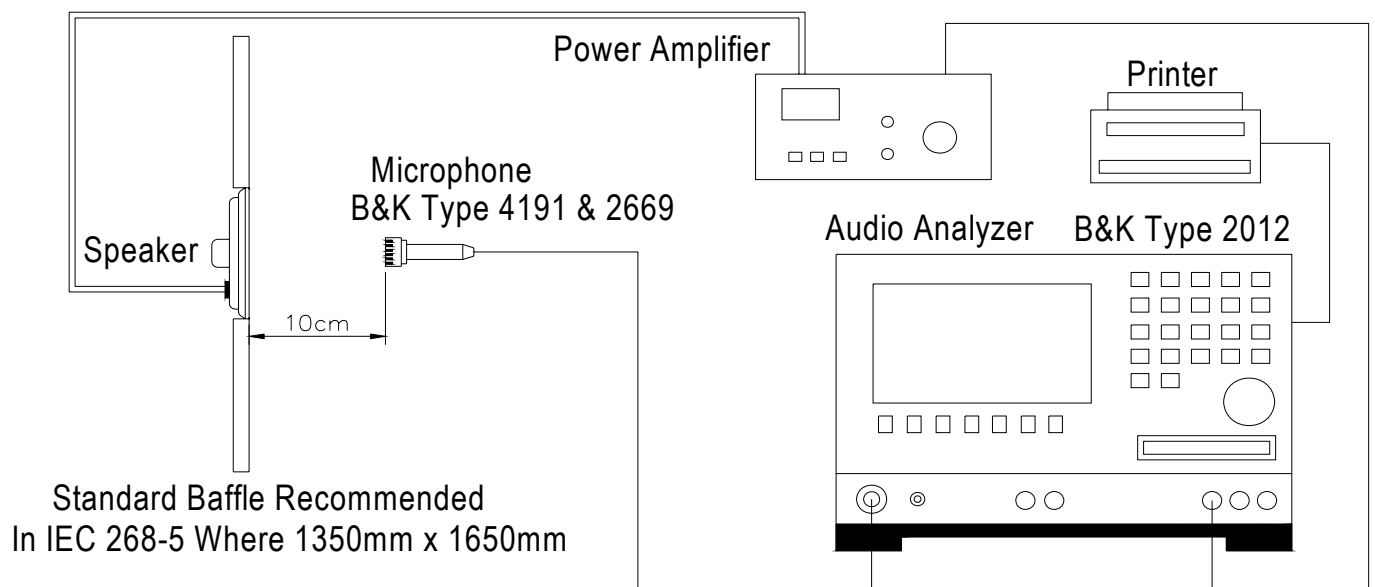

# Frequency Response Curve

X:400.00Hz \*Y:107.45dB ZA:Live Curve SSR Fund.

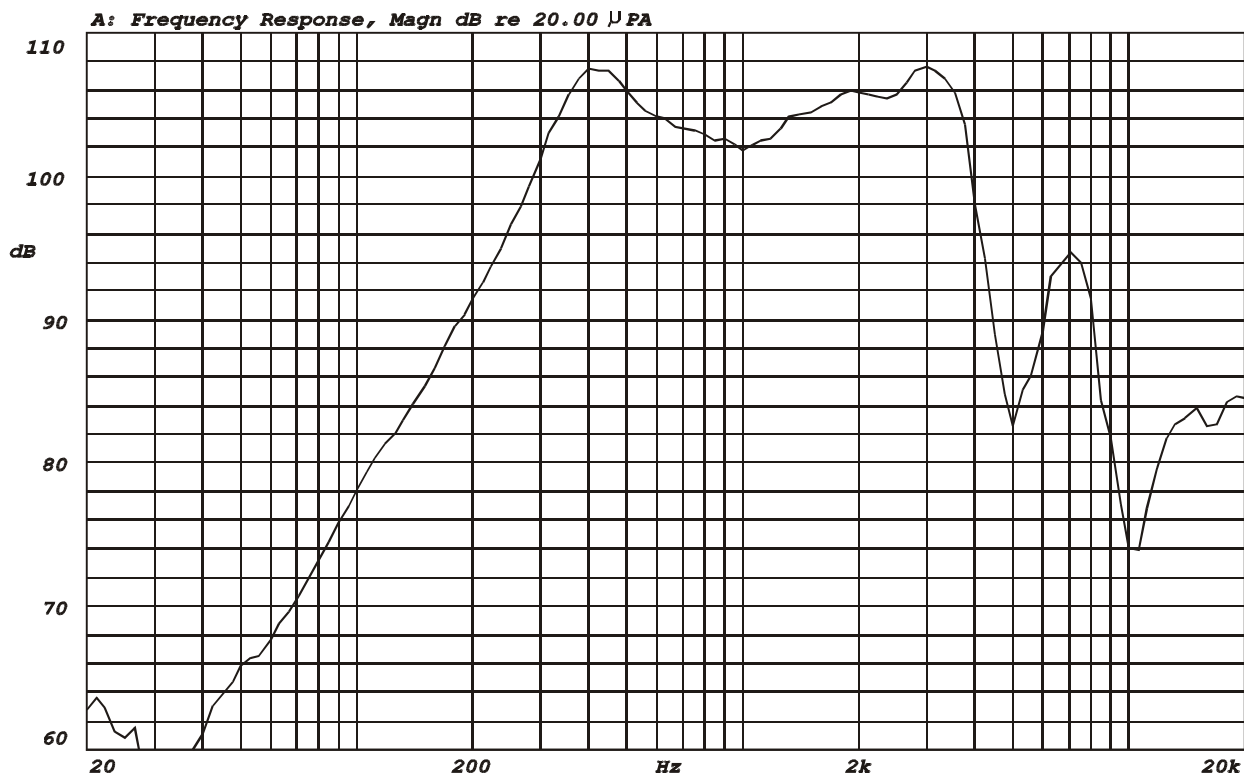

Mode: SSR



# Impedance Curve

IMPEDANCE MEASUREMENTS: Measurement of Impedance  $Z(j\omega)$   
ZA:Live Curve Impedance  $\Omega$

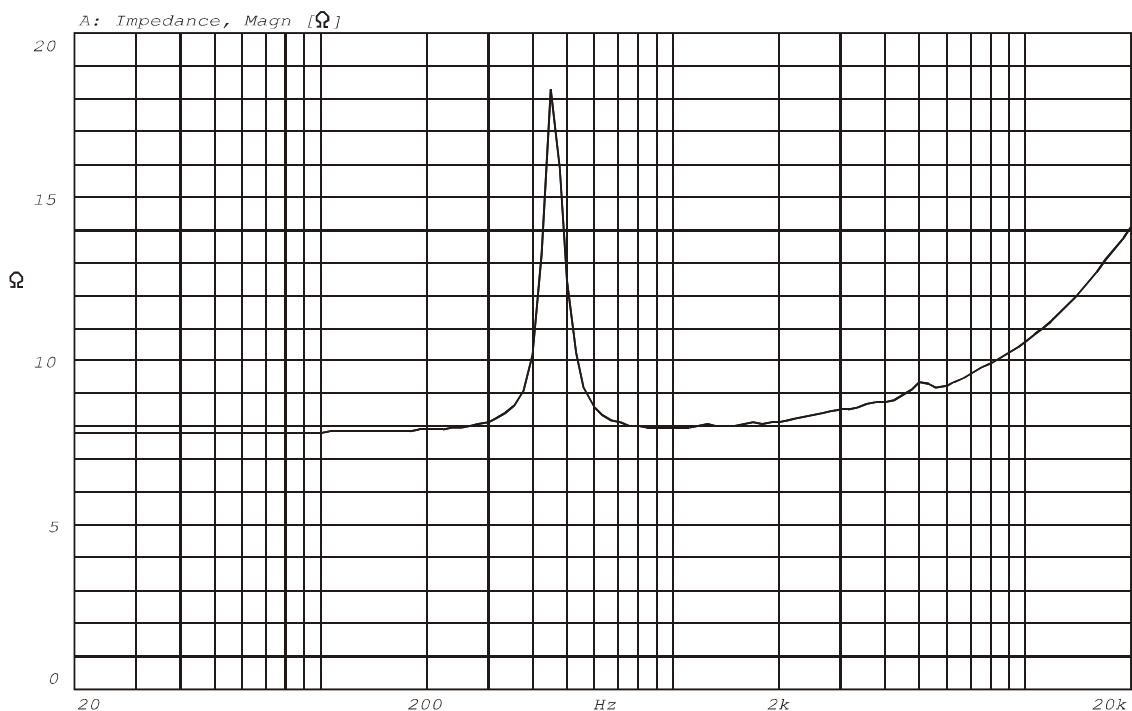

Mode:  $Z(j\omega)$



REV NO.	REVISION NOTE	APPROVAL	DATE
---------	---------------	----------	------

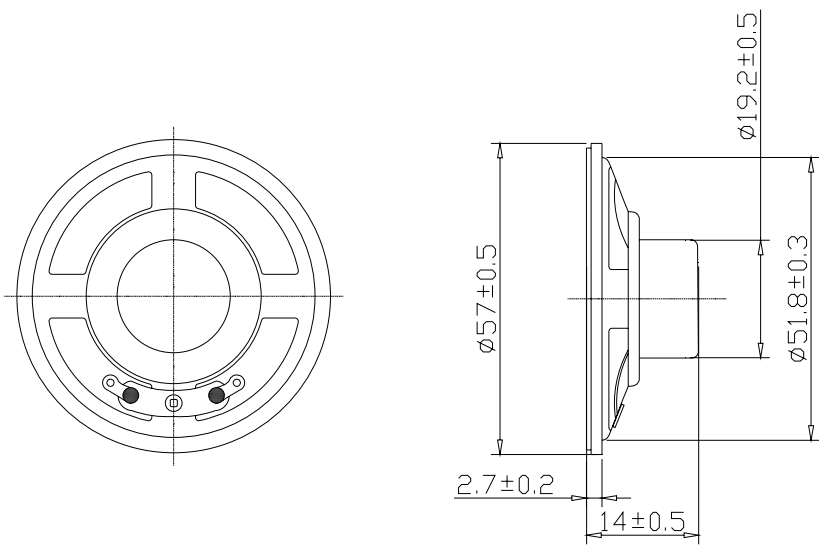

NOTE:

TITLE: <i>DYNAMIC SPEAKER</i>		DRAWN: <i>Lemon</i> 2008/05/14	SCALE: 1:1	SHEET: 1 of 1
PART NO. <i>AK-5708BC-16</i>	<b>1</b> REV	DESIGNED: <i>R&amp;D OF AAT</i>	UNITS: <i>mm</i>	
DWG NO. <i>AEK-08051401</i>		CHECKED:	TOLERANCE $\pm 0.3$	
		APPROVAL:	UNLESS OTHERWISE SPECIFIED: ONE PLACE DECIMAL $\pm$ *** TWO PLACE DECIMAL $\pm$ *** THREE PLACE DECIMAL $\pm$ ***	
		MATERIAL: <i>*****</i>		



**ADVANCED ACOUSTIC TECHNOLOGY CORPORATION**